

# 6 MESAS REFRIGERADAS

## REFRIGERATED COUNTER

### MEUBLE RÉFRIGÉRÉE



#### CARACTERÍSTICAS TÉCNICAS

- Exterior en acero inox AISI-304 18/10, excepto el respaldo
- Interior en acero inox AISI-304 18/10, con aristas curvas y fondo embutido
- Puertas de vidrio con serigrafía mínima gris oscuro con apertura reversible, con sistema de cierre automático y burlete magnético (permanece abierta al superar los 90° de apertura)
- Contrapuerta inox embutida
- Luz interior en modelos puerta de cristal
- Encimera de acero inox AISI-304 18/10 con frente recto y peto trasero sanitario de 100 mm (opcional sin peto según modelo)
- Estantes interiores de varilla en acero plastificado, regulables en altura, sobre apoyos inox
- Pies en tubo de acero inox ajustables en altura 125 200 mm
- Unidad condensadora ventilada y extraíble
- Evaporador sistema tiro forzado, con recubrimiento anticorrosión
- Evaporación automática del agua de descarche de serie, excepto modelos pre-instalación
- Aislamiento de poliuretano inyectado, densidad 40 Kg/m³, bajo GWP y cero efecto ODP
- Control digital de temperatura y descarches, eficiente en la gestión del consumo de energía
- Temperatura de trabajo a 32°C ambiente
- Cajoneras inox refrigeradas desmontables sobre guías telescópicas con sistema autocierre

#### TECHNICAL DATA

- AISI-304 18/10 stainless steel exterior, except the rear side
- AISI-304 18/10 stainless steel interior, stamped bottom and rounded corners
- Glass doors with minimal dark gray serigraphy with reversible opening, with automatic closing system and magnetic weather stripping (remains open when opening more than 90°)
- Rear-door by stamped steel
- Interior light in glass door models
- AISI-304 18/10 stainless steel worktop, with straight front and 100 mm sanitary up stand (optional without up stand depending on model)
- Shelves made of plasticized steel wire, height adjustable by stainless steel supports
- AISI -304 18/10 adjustable legs, 125 to 200 mm
- Removable and fan assisted condenser unit
- Fan assisted evaporator, with anticorrosion coating.
- Automatic evaporation of defrost water ass standard, except models preinstalation
- 40 Kg/m³ density polyurethane insulation, low GWP and zero ODP effect
- Energy efficient digital controller of temperature and defrosts
- Operating temperature 32°C ambient
- Removable stainless refrigerated drawers on telescopic guides with self-closing system

#### CARACTÉRISTIQUES TECHNIQUES

- Extérieur en acier inox AISI 304 18/10, à l'exception de la partie arrière
- Intérieur en acier inox AISI 304 18/10, avec bords incurvés et bac encastré.
- Portes en verre avec sérigraphie minimale gris foncé à ouverture réversible, avec système de fermeture automatique et coupe-froid magnétique (reste ouvert lors d'une ouverture à plus de 90°)
- Contreporte en Inox encastrée
- Lumière intérieure dans les modèles de portes en verre
- Plan de travail en acier inoxydable AISI 304 18/10 avec avant droit et arrière avec bavette de 100mm et évacuation sanitaire (sur option : sans bavette en fonction du modèle)
- Étagères intérieures avec Fils d'acier plastifiés, réglables en hauteur, posées sur soutien en inox.
- Pies en tube d'acier inoxydable réglables en hauteur 125 - 200 mm
- Unité de condensation ventilée extractible
- Evaporateurs avec système de marche forcée et recouvrement anticorrosion.
- Evaporation automatique des eaux de dégivrage en série, sauf les modèles préinstallation.
- Isolation à base de polyuréthane injecté, densité 40 kg/m³, faible GWP et aucun effet ODP.
- Le Contrôle digital de température ainsi que le dégivrage automatique œuvre à une meilleure gestion de la consommation énergétique.
- Température ambiante de travail à 32°C
- Amovibles tiroirs réfrigérés inoxydable sur glissières télescopiques avec système de fermeture automatique



**BMR** Página 261  
Mesas frías SNACK  
Counter SNACK  
Meuble SNACK



**MP / MS** Página 285  
Mesa fría saladette GN 1/1  
GN 1/1 Saladette counter  
Meuble saladette GN 1/1



**CMR** Página 265  
Frente mostrador SNACK  
SNACK front desk  
Réception SNACK



**DMFE** Página 287  
Mesa fría salad-cheff GN 1/1  
GN 1/1 salad-cheff counter  
Meuble salad-cheff GN 1/1



**CMC** Página 267  
Frente mostrador cafetero compacto  
Front desk compact coffee  
Bureau café compact avant



**DMFK** Página 289  
Mesa fría GN 1/1 fast food  
GN 1/1 fast food counter  
Meuble fast food GN 1/1



**ECM** Página 269  
Estantería frente mostrador  
Shelf front desk  
Avant de conservation bureau



**MEI** Página 291  
Mesa fría sushi-cheff  
Sushi-cheff counter  
Meuble sushi-cheff



**DHMRG** Página 271  
Mesa fría GN 1/1 alta eficiencia  
GN 1/1 counter high efficiency  
Meuble GN 1/1 haute efficacité



**DMFPP** Página 293  
Mesa fría pizza compacta  
Compact pizza counter  
Meuble compacte



**BRG** Página 273  
Mesa fría GN 1/1  
GN 1/1 counter  
Meuble GN 1/1



**MPC** Página 295  
Mesa fría pizza  
Pizza counter  
Meuble pizza



**BCR** Página 277  
Mesa fría GN 1/1 bajo cocina  
GN 1/1 under kitchen counter  
Sous cuisine meuble GN 1/1



**IE** Página 301  
Expositor de ingredientes  
Exhibitor ingredients  
Ingrédients d'exposants



**BPR** Página 281  
Mesa pastelera  
Cake counter  
Meuble pâtisserie

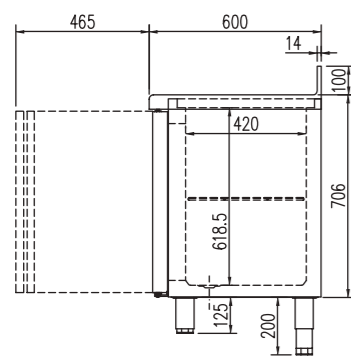

TOMA DE DESAGÜE · DRAIN OUTLET · DRAIN FAIRE



DETALLE FREGADERO · DETAIL SINK · DETAIL ÉVIER



BMR-200-2/3

Cajonera triple lado motor, es necesario instalar evaporadores centrales  
Triple sided motor chest, it is necessary to install central evaporators  
Coffre moteur à trois côtés, il est nécessaire d'installer des évaporateurs centraux

Ver características técnicas en página 250 / See technical data in page 250 / Voir caractéristiques techniques page 250

Modelo Model Modèle	Largo Length Longueur mm	Alto Height Hauteur mm	Fondo Depth Profondeur mm	Rango Range Gamme	Estantes Shelves Étagères	Capacidad Capacity Exposition L	Voltaje Voltage Tension	Refrig. Coolant Frigorigène	Potencia Frig. Frig Power Puissance Frig. W	Consumo Nominal Nominal Consumption Consommation Nominale W	Rango Range Gamme	clase climate 2015/1094 EN16825 Rango Range Gamme
BMR-150	1495	850	600	-2°C +8°C	2	245	230 V - 50 Hz	R-290	502	235	B	5 (40°C 40%)
BMRV-150	1495	850	600	-2°C +8°C	2	245	230 V - 50 Hz	R-290	502	243	-	5 (40°C 40%)
BMR-200	2020	850	600	-2°C +8°C	3	380	230 V - 50 Hz	R-290	502	238	B	5 (40°C 40%)
BMRV-200	2020	850	600	-2°C +8°C	3	380	230 V - 50 Hz	R-290	502	251	-	5 (40°C 40%)
BMR-250	2545	850	600	-2°C +8°C	4	516	230 V - 50 Hz	R-290	845	355	C	5 (40°C 40%)
BMRV-250	2545	850	600	-2°C +8°C	4	516	230 V - 50 Hz	R-290	845	357	-	5 (40°C 40%)
BMR-300	3070	850	600	-2°C +8°C	5	651	230 V - 50 Hz	R-290	845	355	C	5 (40°C 40%)
BMRV-300	3070	850	600	-2°C +8°C	5	651	230 V - 50 Hz	R-290	845	380	-	5 (40°C 40%)
BMC-150	1495	850	600	-20°C -15°C	2	245	230 V - 50 Hz	R-290	606	535	D	5 (40°C 40%)
BMCV-150	1495	850	600	-20°C -15°C	2	245	230 V - 50 Hz	R-290	606	544	-	4 (30°C 55%)
BMC-200	2020	850	600	-20°C -15°C	3	380	230 V - 50 Hz	R-290	606	556	E	4 (30°C 55%)
BMCV-200	2020	850	600	-20°C -15°C	3	380	230 V - 50 Hz	R-290	606	548	-	4 (30°C 55%)

OPCIONES · OPTIONS · OPTIONS

Parrilla adicional 405x525 central	405x525 central extra shelf central	Grille additionnelle 405x525 central	25 €
Parrilla adicional 405x460 lateral	405x460 side extra shelf	Grille additionnelle 405x460 latéral	25 €
Cajonera doble inox, auto-cierre	Double drawers set, self-closing	Tiroirs doubles inox, fermeture automatique	476€ x set
Cajonera triple inox, auto-cierre	Triple drawers set, self-closing	Tiroirs triple inox, fermeture automatique	710 € x set
Cerradura puerta inox	Solid door lock	Serrure à porte inox	25 € x ud
Cerradura puerta cristal	Glass door lock	Serrure à porte en verre	61 € x ud
Motor lado izquierdo	Left side engine	Moteur côté gauche	73 €
Encimera sin peto	No upstand worktop	Plan de travail sans panneau de protection	0 €
Set 4 ruedas	4 Castors set	Jeu 4 roulettes	98 € x set
Set 6 ruedas	6 Castors set	Jeu 6 roulettes	146 € x set
Evaporación automática	Automatic evaporation	Évaporation automatique	116 €
Registrador de alarmas HACCP	HACCP alarm recorder	Enregistreur d'alarme HACCP	consultar - consult - consulter
Tropicalizado 43°C	Tropicalized to 43°C	Tropicalisé 43°C	consultar - consult - consulter
Respaldo inox	Stainless steel rear side	Soutien en inox	consultar - consult - consulter
230V 60hz / 115v 60hz	230V 60hz / 115v 60hz	230V 60hz / 115v 60hz	consultar - consult - consulter

Características técnicas y constructivas sujetas a variación sin previo aviso. / We reserve the right to change specifications without prior notice. / Sujet technique et la conception de modifications sans préavis.



BMR-200



DETALLE TIRADOR  
DETAIL HANDLE  
DETAIL TIREUR



BMR-200-V

BMR-150 2.283 €	BMR-200 2.708 €	BMR-250 3.204 €	BMR-300 3.835 €
BMC-150 2.896 €	BMC-200 3.345 €		
BMR-150-V 2.678 €	BMR-200-V 3.237 €	BMR-250-V 3.886 €	BMR-300-V 4.632 €
BMC-150-V 3.272 €	BMC-200-V 3.920 €		
BMR-150-F 2.581 €	BMR-200-F 2.989 €	BMR-250-F 3.512 €	BMR-300-F 4.236 €

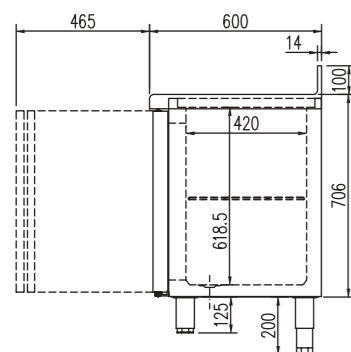

**BMRP-220-2/3**



DETALLE PREINSTALACION  
detailed pre-installation  
détailée de pré-installation

Los modelos preinstalación NO incluyen valvulería, capilar y bandeja de evaporación automática  
The preinstallation models do not include valves, capillary and automatic evaporation tray  
Les modèles de préinstallation ne comprennent pas les vannes, capillaire et le plateau d'évaporation automatique

**MESA FRÍA SNACK REFRIGERACIÓN Y CONGELADOS PRE-INSTALACIÓN**

SNACK COUNTER, CHILLER AND FREEZER FOR REMOTE CONDENSER UNIT

TABLE RÉFRIGÉRÉE SNACKS: RÉFRIGÉRATION ET CONGÉLATION: PRÉ-INSTALLATION



**BMRP-220**

Ver características técnicas en página 250 / See technical data in page 250 / Voir caractéristiques techniques page 250

Modelo Model Modèle	Largo Length Longueur mm	Alto Height Hauteur mm	Fondo Depth Profondeur mm	Potencia Frig. Frig Power Puissance Frig. W	Capacidad Capacity Exposition L	Peso Neto Net Weight Poid Net Kg	Estantes x set Shelves x set Étagères x set	Voltaje Voltage Tension	Refrig. Coolant Frigorigène	Rango Range Gamme
BMRP/BMRPV-120	1195	850	600	300	246	68	2	230 V - 50 Hz	R-134a	-2°C+8°C
BMRP/BMRPV-170	1720	850	600	356	380	89	3	230 V - 50 Hz	R-134a	-2°C+8°C
BMRP/BMRPV-220	2245	850	600	485	516	110	4	230 V - 50 Hz	R-134a	-2°C+8°C
BMRP/BMRPV-270	2770	850	600	485	651	135	5	230 V - 50 Hz	R-134a	-2°C+8°C
BMCP/BMCPV-120	1195	850	600	353	245	68	2	230 V - 50 Hz	R-449A	-20°C-15°C
BMCP/BMCPV-170	1720	850	600	452	380	89	3	230 V - 50 Hz	R-449A	-20°C-15°C
BMCP/BMCPV-220	2245	850	600	610	516	110	4	230 V - 50 Hz	R-449A	-20°C-15°C



**BMRP-170-V**

**OPCIONES - OPTIONS - OPTIONS**

Parrilla adicional 405x525 central	405x525 central extra shelf	Grille additionnelle 405x525 central	25 €
Parrilla adicional 405x460 lateral	405x460 side extra shelf	Grille additionnelle 405x460 latéral	25 €
Cajonera doble inox, auto-cierre	Double drawers set, self-closing	Tiroirs doubles inox, fermeture automatique	476€ x set
Cajonera triple inox, auto-cierre	Triple drawers set, self-closing	Tiroirs triple inox, fermeture automatique	710 € x set
Cerradura puerta inox	Solid door lock	Serrure à porte inox	25 € x ud
Cerradura puerta cristal	Glass door lock	Serrure à porte en verre	61 € x ud
Motor lado izquierdo	Left side engine	Moteur côté gauche	73 €
Encimera sin peto	No upstand worktop	Plan de travail sans panneau de protection	0 €
Set 4 ruedas	4 Castors set	Jeu 4 roulettes	98 € x set
Set 6 ruedas	6 Castors set	Jeu 6 roulettes	146 € x set
Evaporación automática	Automatic evaporation	Évaporation automatique	116 €
Registrador de alarmas HACCP	HACCP alarm recorder	Enregistreur d'alarme HACCP	consultar - consult - consulter
Tropicalizado 43°C	Tropicalized to 43°C	Tropicalisé 43°C	consultar - consult - consulter
Respaldo inox	Stainless steel rear side	Soutien en inox	consultar - consult - consulter
230V 60hz / 115v 60hz	230V 60hz / 115v 60hz	230V 60hz / 115v 60hz	consultar - consult - consulter

BMRP-120 <b>1.849 €</b>	BMRP-170 <b>2.302 €</b>	BMRP-220 <b>2.666 €</b>	BMRP-270 <b>3.163 €</b>
BMCP-120 <b>2.037 €</b>	BMCP-170 <b>2.533 €</b>	BMCP-220 <b>2.916 €</b>	
BMRP-120-V <b>2.160 €</b>	BMRP-170-V <b>2.754 €</b>	BMRP-220-V <b>3.250 €</b>	BMRP-270-V <b>3.892 €</b>
BMCP-120-V <b>2.479 €</b>	BMCP-170-V <b>3.180 €</b>	BMCP-220-V <b>3.761 €</b>	

Características técnicas y constructivas sujetas a variación sin previo aviso. / We reserve the right to change specifications without prior notice. / Sujet technique et la conception de modifications sans préavis.

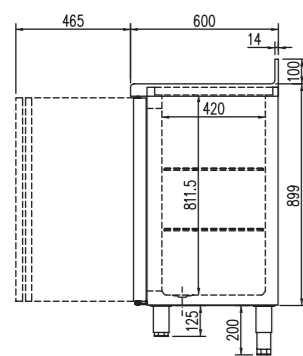

CMRP-220



DETALLE CAJON TOLVA  
HOPPER DRAWER DETAIL  
DÉTAIL DU TIROIR DE TRÉMIÉ



DETALLE TIRADOR  
DETAIL HANDLE  
DETAIL TIREUR

Los modelos preinstalación NO incluyen valvulería, capilar y bandeja de evaporación automática  
The preinstallation models do not include valves, capillary and automatic evaporation tray  
Les modèles de préinstallation ne comprennent pas les vannes, capillaire et le plateau d'évaporation automatique  
Ver características técnicas en página 250 / See technical data in page 250 / Voir caractéristiques techniques page 250

Modelo Model Modèle	Largo Length Longueur mm	Alto Height Hauteur mm	Fondo Depth Profondeur mm	Rango Range Gamme	Estantes Shelves Étagères	Capacidad Capacity Exposition L	Voltaje Voltage Tension	Refrig. Coolant Frigorigène	Potencia Frig. Frig Power Puissance Frig. W	Consumo Nominal Nominal Consumption Consommation Nominale W	GCE EEC 2015/ 1094 EN16825	clase climate 2015/1094 EN16825
CMR-150	1495	1040	600	-2°C +8°C	4	325	230 V - 50 Hz	R-290	502	235	A	5 (40°C 40%)
CMRV-150	1495	1040	600	-2°C +8°C	4	325	230 V - 50 Hz	R-290	502	247	-	5 (40°C 40%)
CMR-200	2020	1040	600	-2°C +8°C	6	504	230 V - 50 Hz	R-290	502	238	B	5 (40°C 40%)
CMRV-200	2020	1040	600	-2°C +8°C	6	504	230 V - 50 Hz	R-290	502	255	-	5 (40°C 40%)
CMR-250	2545	1040	600	-2°C +8°C	8	684	230 V - 50 Hz	R-290	845	340	B	5 (40°C 40%)
CMRV-250	2545	1040	600	-2°C +8°C	8	684	230 V - 50 Hz	R-290	845	363	-	5 (40°C 40%)
CMR-300	3070	1040	600	-2°C +8°C	10	863	230 V - 50 Hz	R-290	845	355	B	5 (40°C 40%)
CMRV-300	3070	1040	600	-2°C +8°C	10	863	230 V - 50 Hz	R-290	845	384	-	5 (40°C 40%)
CMRP / CMRPV-120	1195	1040	600	-2°C +8°C	4	325	230 V - 50 Hz	R-134a	300	-	-	
CMRP / CMRPV-170	1720	1040	600	-2°C +8°C	6	504	230 V - 50 Hz	R-134a	356	-	-	
CMRP / CMRPV-220	2245	1040	600	-2°C +8°C	8	684	230 V - 50 Hz	R-134a	485	-	-	
CMRP / CMRPV-270	2770	1040	600	-2°C +8°C	10	863	230 V - 50 Hz	R-134a	485	-	-	

Posibilidad de fabricación en rango de temperatura -20 -15°C / Possibility of manufacturing in temperature range -20 -15°C / Possibilité de fabrication dans une plage de température -20 -15°C

OPCIONES - OPTIONS - OPTIONS

Parrilla adicional 405x525 central	405x525 central extra shelf	Grille additionnelle 405x525 central	25 €
Parrilla adicional 405x460 lateral	405x460 side extra shelf	Grille additionnelle 405x460 latéral	25 €
Cajonera doble inox, auto-cierre	Double drawers set, self-closing	Tiroirs doubles inox, fermeture automatique	742 € x set
Cajonera doble cristal, auto-cierre	Double glass drawers set, self-closing	Tiroirs doubles en verre, fermeture automatique	871 € x set
Cajonera triple inox, auto-cierre	Triple drawers set, self-closing	Tiroirs triple inox, fermeture automatique	933 € x set
Cerradura puerta inox	Solid door lock	Serrure à porte inox	25 € x ud
Motor lado izquierdo	Left side engine	Moteur côté gauche	73 €
Encimera sin peto	No upstand worktop	Plan de travail sans panneau de protection	0 €
Set 4 ruedas	4 Castors set	Jeu 4 roulettes	98€ x set
Set 6 ruedas	6 Castors set	Jeu 6 roulettes	146 € x set
Evaporación automática	Automatic evaporation	Évaporation automatique	116 €
Registrador de alarmas HACCP	HACCP alarm recorder	Enregistreur d'alarme HACCP	consultar - consult - consulter
Respaldo inox	Stainless steel rear side	Soutien en inox	consultar - consult - consulter
Tropicalizado 43°C	Tropicalized to 43°C	Tropicalisé 43°C	consultar - consult - consulter
Exterior blanco o negro	Black or white exterior	Extérieur noir ou blanc	consultar - consult - consulter
230V 60hz / 115v 60hz	230V 60hz / 115v 60hz	230V 60hz / 115v 60hz	consultar - consult - consulter

Características técnicas y constructivas sujetas a variación sin previo aviso. / We reserve the right to change specifications without prior notice. / Sujet technique et la conception de modifications sans préavis.

FRENTE MOSTRADOR SNACK, REFRIGERACIÓN Y PREINSTALACIÓN

SNACK BACK BAR COUNTER, CHILLER AND PREINSTALLATION  
COMPTOIR AVANT SNACK, RÉFRIGÉRATION ET LA PRÉINSTALLATION



CMR-250

SERIGRAFÍA PERIMETRAL  
PERIMETRAL SERIGRAPHY  
SÉRIGRAPHIE PÉRIMÉTRIQUE



LED



CMR-250-V

CMR-150 2.567 €	CMR-200 3.089 €	CMR-250 3.598 €	CMR-300 4.156 €
CMR-150-V 3.008 €	CMR-200-V 3.686 €	CMR-250-V 4.391 €	CMR-300-V 5.082 €
CMRP-120 1.965 €	CMRP-170 2.433 €	CMRP-220 2.857 €	CMRP-270 3.398 €
CMRP-120-V 2.360 €	CMRP-170-V 3.008 €	CMRP-220-V 3.589 €	CMRP-270-V 4.308 €

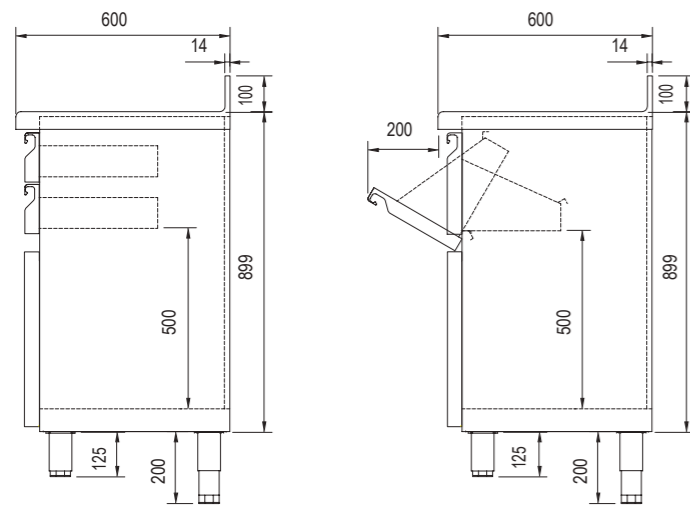

**CARACTERÍSTICAS TÉCNICAS**

- Módulos de diseño compacto
- Exterior y estantes en acero inox AISI-304 18/10, excepto el respaldo
- Respaldo en acero plastificado
- Encimera de acero inox AISI-304 18/10 con frente curvo y peto trasero sanitario de 100 mm (Opcional sin peto)
- Cajones con guías de rodamientos
- Cajón tolva para café, desmontable
- Cajones y tolva, son intercambiables
- Pies en tubo de acero inox ajustables en altura 125-200 mm
- Pueden fabricarse, bajo pedido, en diferentes medidas

**TECHNICAL DATA**

- Compact designed modules
- AISI-304 18/10 stainless steel exterior and shelf, except the rear side AISI-304 18/10 stainless steel exterior and shelves, except the rear side
- Rear panel in plasticized steel
- AISI-30418/10 stainless steel worktop, with rounded front and 100 mm sanitary up stand (optional without up stand)
- Drawers with slides
- Detachable coffee-grounds hopper
- Interchangeable drawers (auxiliary and coffee)
- AISI -304 18/10 adjustable legs, 125 to 200 mm
- Can be produced on request, in different measures

**CARACTÉRISTIQUES TECHNIQUES**

- Modules de design compact
- Extérieur et étagères en acier inoxydable AISI 304 18/10, sauf la partie arrière
- Dossier en acier plastifié
- Plan de travail en acier inoxydable AISI 304 18/10, avec partie avant inclinée et panneau de protection arrière de 100mm (possible sans panneau de protection sur option)
- Tiroirs avec rails à roulement
- Tiroir-trémie de café amovible.
- Tiroir et trémie de café sont interchangeables.
- Pieds en tube d'acier inoxydable, réglables en hauteur 125-200mm
- Ce produit peut se fabriquer en différentes dimensions, sur commande.



CMC-50-T



CMC-90



CMC-140

	→	↑	↗	👜	📦	🗑️	🚪
Modelo	Largo	Alto	Fondo	Peso Neto	Cajones	Tolva	Puertas
Model	Length	Height	Depth	Net Weight	Drawers	Hopper	Doors
Modèle	Longueur	Hauteur	Profondeur	Poid Net	Tiroirs	Trémie	Portes
	mm	mm	mm	Kg			
CMC-50-T	475	1040	600	28	0	1	1
CMC-50-C	475	1040	600	28	2	0	1
CMC-90	915	1040	600	55	2	1	2
CMC-140	1375	1040	600	85	4	1	2

**DETALLE · DETAIL · DETAIL**



CMR-150 + CMC-50-T  
 Encimera especial  
 Special worktop  
 Surface spéciale

Características técnicas y constructivas sujetas a variación sin previo aviso. / We reserve the right to change specifications without prior notice. / Sujet technique et la conception de modifications sans préavis.

CMC-50-T <b>557 €</b>	CMC-50-C <b>557 €</b>	CMC-90 <b>930 €</b>	CMC-140 <b>1.332 €</b>

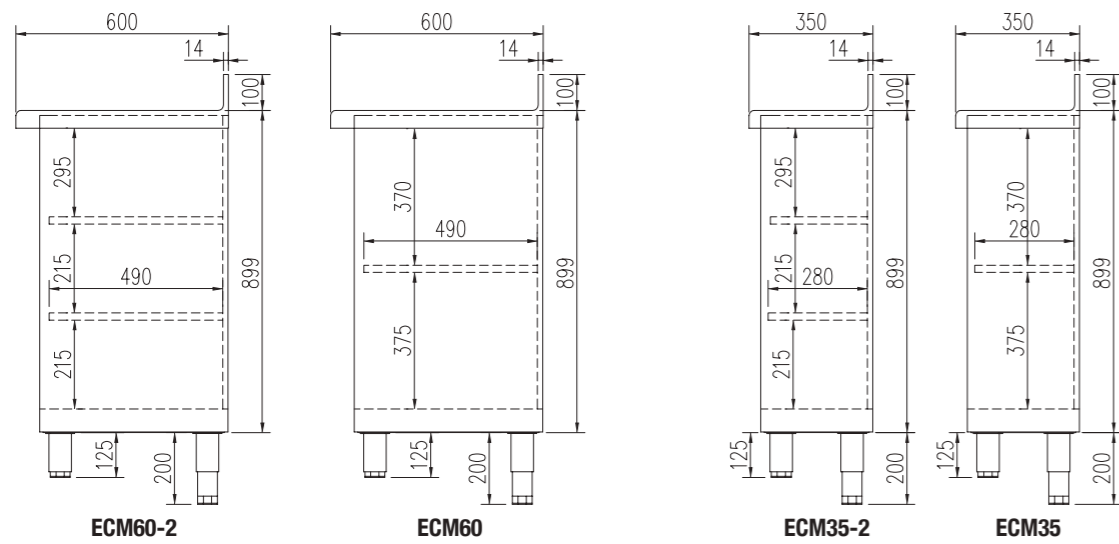

ECM60-200-2



ECMC35-100

**CARACTERÍSTICAS TÉCNICAS**

- Exterior y estantes en acero inox AISI-304 18/10, excepto el respaldo
- Respaldo en acero plastificado
- Encimera de acero inox AISI-304 18/10 con frente curvo y peto trasero sanitario de 100 mm (Opcional sin peto)
- Pies en tubo de acero inox ajustables en altura 125 200 mm
- ECM-2: de serie dos estantes
- Pueden fabricarse, bajo pedido, en diferentes medidas

**TECHNICAL DATA**

- AISI-304 18/10 stainless steel exterior and shelves, except the rear side
- Rear panel in plasticized steel
- AISI-30418/10 stainless steel worktop, with rounded front and 100 mm sanitary up stand (optional without up stand)
- AISI -304 18/10 adjustable legs, 125 to 200mm
- ECM-2: two shelves as standard
- Can be produced on request, in different measures

**CARACTÉRISTIQUES TECHNIQUES**

- Extérieur et intérieur en acier inoxydable AISI 304 18/10, sauf la partie arrière
- Dossier en acier plastifié
- Plan de travail en acier inoxydable AISI-304 18/10, avec partie avant inclinée et panneau de protection arrière de 100mm (possible sans panneau de protection sur option)
- Pieds en tube d'acier inoxydable, réglables en hauteur 125-200mm
- ECM 2 : fournie de série avec deux étagères.
- Ce produit peut se fabriquer en différentes dimensions, sur commande

Modelo Model Modèle	Largo Length Longueur mm	Alto Height Hauteur mm	Fondo Depth Profondeur mm	Estantes Shelves Étagères
ECM60-100	990	1040	600	1
ECM60-150	1495	1040	600	1
ECM60-200	2020	1040	600	1
ECM35-100	990	1040	350	1
ECM35-150	1495	1040	350	1
ECM35-200	2020	1040	350	1

**DETALLE · DETAIL · DETAIL**

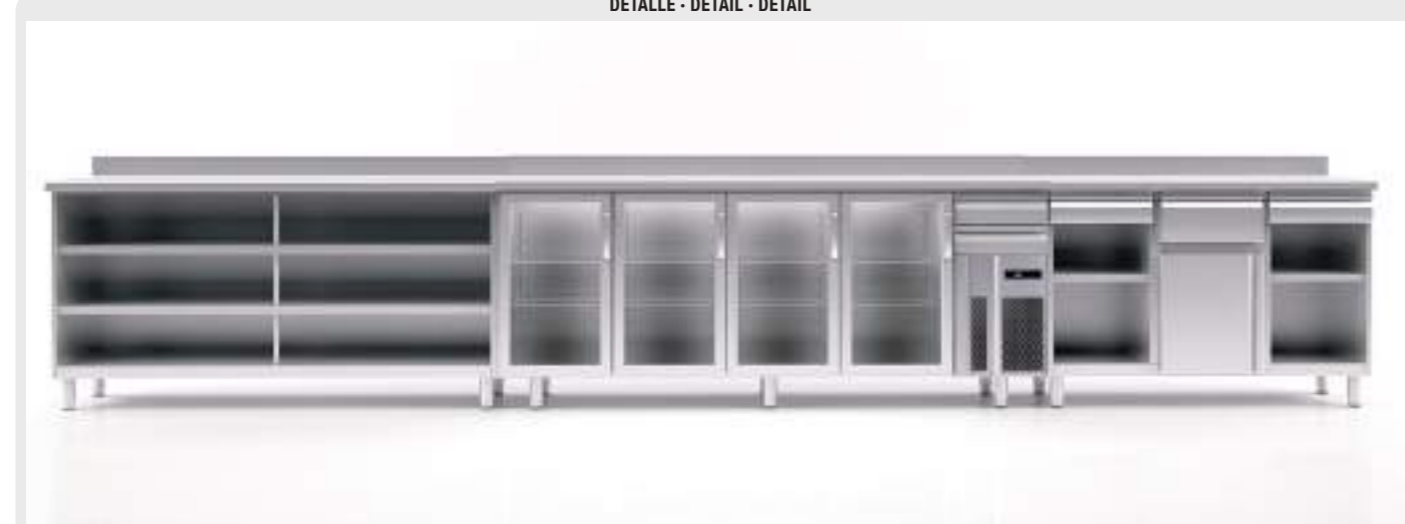

Características técnicas y constructivas sujetas a variación sin previo aviso. / We reserve the right to change specifications without prior notice. / Sujet technique et la conception de modifications sans préavis.

	ECM35-100 <b>502 €</b>		ECM35-150 <b>701 €</b>		ECM35-200 <b>899 €</b>		ECM60-100 <b>655 €</b>		ECM60-150 <b>811 €</b>		ECM60-200 <b>1.006 €</b>
	ECM35-100-2 <b>569 €</b>		ECM35-150-2 <b>763 €</b>		ECM35-200-2 <b>943 €</b>		ECM60-100-2 <b>757 €</b>		ECM60-150-2 <b>890 €</b>		ECM60-200-2 <b>1.104 €</b>

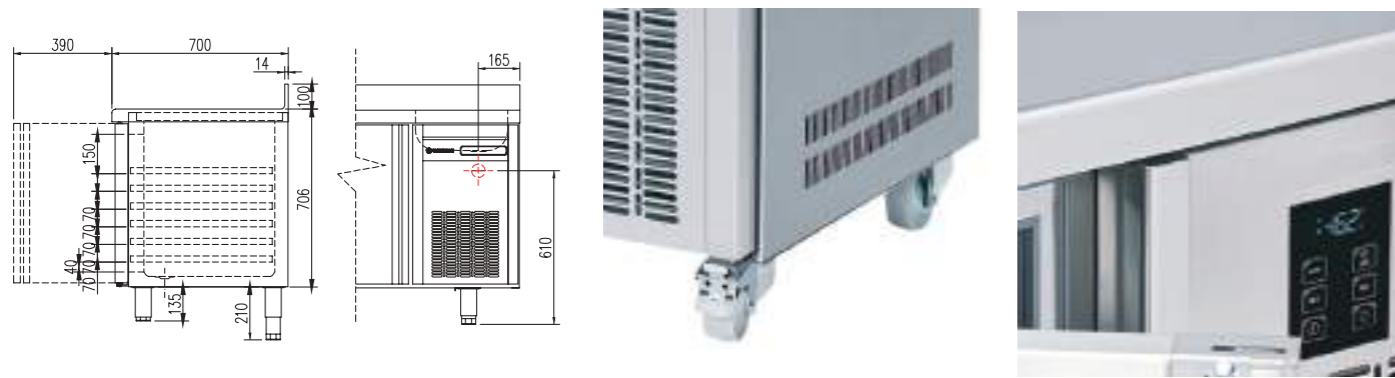

**A**  
**0,92**  
KW/24h

DHMRG-135



DETALLE TIRADOR  
DETAIL HANDLE  
DETAIL TIREUR

**A**  
**1,36**  
KW/24h



DHMRG-180

Ver características técnicas en página 250 / See technical data in page 250 / Voir caractéristiques techniques page 250

Modelo Model Modèle	Largo Length Longueur mm	Alto Height Hauteur mm	Fondo Depth Profondeur mm	Rango Range Gamme	Estantes Shelves Étagères	Pares de guías Sets of slides Kit de guides	Capacidad Capacity Exposition L	Voltaje Voltage Tension	Refrig. Coolant Frigorigène	Potencia Frig. Frig Power Puissance Frig. W	Consumo Nominal Nominal Consumption Consommation Nominale W	Rango Range Gamme	Rango Range Gamme
DHMRG-135	1345	850	700	-2°C +8°C	2	2	255	230 V - 50 Hz	R-290	502	187	A+	5 40°C 40%
DHMRG-180	1795	850	700	-2°C +8°C	3	3	399	230 V - 50 Hz	R-290	502	192	A	5 40°C 40%

**OPCIONES · OPTIONS · OPTIONS**

Parrilla suplemento	Suplement extra shelf	Grille additionnelle Supplement	21 € x ud
Parrilla adicional 530 X 325 GN1/1	530 X 325 GN1/1 extra shelf	Grille additionnelle 530 X 325 GN1/1	28 € x ud
Set adicional guías GN 1/1 340500006	GN 1/1 slides extra set	Kit supplémentaire de guides GN 1/1	30 € x set
Cajonera doble inox, auto-cierre	Double drawers set, self-closing	Tiroirs doubles inox, fermeture automatique	599 € x set
Cajonera triple inox, auto-cierre	Triple drawers set, self-closing	Tiroirs triple inox, fermeture automatique	790 € x set
Cerradura puerta inox	Solid door lock	Serrure à porte inox	25 € x ud
Cerradura puerta cristal	Glass door lock	Serrure à porte en verre	61 € x ud
Motor lado izquierdo	Left side engine	Moteur côté gauche	73 €
Encimera sin peto	No upstand worktop	Plan de travail sans panneau de protection	0 €
Set 4 ruedas	4 Castors set	Jeu 4 roulettes	98 € x set
Set 6 ruedas	6 Castors set	Jeu 6 roulettes	146 € x set
Evaporación automática	Automatic evaporation	Évaporation automatique	116 €
Registrador de alarmas HACCP	HACCP alarm recorder	Enregistreur d'alarme HACCP	consultar - consult - consulter
Tropicalizado 43°C	Tropicalized to 43°C	Tropicalisé 43°C	consultar - consult - consulter
Respaldo inox	Stainless steel rear side	Soutien en inox	consultar - consult - consulter
230V 60hz / 115v 60hz	230V 60hz / 115v 60hz	230V 60hz / 115v 60hz	consultar - consult - consulter

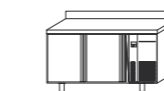

DHMRG-135 **3.169 €**

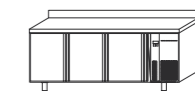

DHMRG-180 **3.638 €**

Características técnicas y constructivas sujetas a variación sin previo aviso. / We reserve the right to change specifications without prior notice. / Sujet technique et la conception de modifications sans préavis.

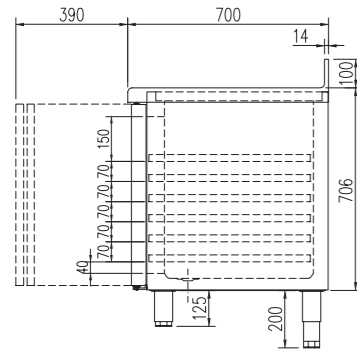

BRG-180-2/3



DETALLE FREGADERO - DETAIL SINK - DETAIL ÉVIER



BRG-180

Ver características técnicas en página 250 / See technical data in page 250 / Voir caractéristiques techniques page 250

\* Gas opcional / \* Optional gas / \* Gaz optionnel

Modelo Model	Largo Length Longueur mm	Alto Height Hauteur mm	Fondo Depth Profondeur mm	Rango Range Gamme	Estantes Shelves Étagères	Pares de guías Sets of slides Kit de guides	Capacidad Capacity Exposition L	Voltaje Voltage Tension	Refrig. Coolant Frigorigène	Potencia Frig. Frig Power Puissance Frig. W	Consumo Nominal Nominal Consumption Consommation Nominale W	Rango Range Gamme	Rango Range Gamme
BRG-135	1345	850	700	-2°C +8°C	2	2	255	230 V - 50 Hz	R-290	502	235	B	5 (40°C 40%)
BRGV-135	1345	850	700	-2°C +8°C	2	2	255	230 V - 50 Hz	R-290	502	246	-	5 (40°C 40%)
BRG-180	1795	850	700	-2°C +8°C	3	3	399	230 V - 50 Hz	R-290	502	238	B	5 (40°C 40%)
BRGV-180	1795	850	700	-2°C +8°C	3	3	399	230 V - 50 Hz	R-290	502	246	-	5 (40°C 40%)
BRG-225	2245	850	700	-2°C +8°C	4	4	543	230 V - 50 Hz	R-290	845	340	C	5 (40°C 40%)
BRGV-225	2245	850	700	-2°C +8°C	4	4	543	230 V - 50 Hz	R-290	845	352	-	5 (40°C 40%)
BRG-270	2695	850	700	-2°C +8°C	5	5	686	230 V - 50 Hz	R-290	845	355	C	5 (40°C 40%)
BRGV-270	2695	850	700	-2°C +8°C	5	5	686	230 V - 50 Hz	R-290	845	369	-	5 (40°C 40%)
BCG-135	1345	850	700	-20°C -15°C	2	2	255	230 V - 50 Hz	R-290	606	535	D	5 (40°C 40%)
BCGV-135	1345	850	700	-20°C -15°C	2	2	255	230 V - 50 Hz	R-290	606	540	-	4 (30°C 55%)
BCG-180	1795	850	700	-20°C -15°C	3	3	399	230 V - 50 Hz	R-290	606	556	D	4 (30°C 55%)
BCGV-180	1795	850	700	-20°C -15°C	3	3	399	230 V - 50 Hz	R-290	606	544	-	4 (30°C 55%)



BRG-225-V

EJEMPLO CUBETAS GN Y DOTACIÓN EXTRA  
SAMPLE TRAYS GN AND EXTRA EQUIPMENT  
EXEMPLE BACS GN ET EQUIPEMENTS COMPLÉMENTAIRES

OPCIONES · OPTIONS · OPTIONS

Parrilla suplemento	Supplement extra shelf	Grille additionnelle Supplement	21 € x ud
Parrilla adicional 530 X 325 GN1/1	530 X 325 GN1/1 extra shelf	Grille additionnelle 530 X 325 GN1/1	28 € x ud
Set adicional guías GN 1/1 340500006	GN 1/1 slides extra set	Kit supplémentaire de guides GN 1/1	30 € x set
Cajonera doble inox, auto-cierre	Double drawers set, self-closing	Tiroirs doubles inox, fermeture automatique	599 € x set
Cajonera triple inox, auto-cierre	Triple drawers set, self-closing	Tiroirs triple inox, fermeture automatique	790 € x set
Cerradura puerta inox	Solid door lock	Serrure à porte inox	25 € x ud
Cerradura puerta cristal	Glass door lock	Serrure à porte en verre	61 € x ud
Motor lado izquierdo	Left side engine	Moteur côté gauche	73 €
Encimera sin peto	No upstand worktop	Plan de travail sans panneau de protection	0 €
Set 4 ruedas	4 Castors set	Jeu 4 roulettes	98 € x set
Set 6 ruedas	6 Castors set	Jeu 6 roulettes	146 € x set
Evaporación automática	Automatic evaporation	Évaporation automatique	116 €
Registrador de alarmas HACCP	HACCP alarm recorder	Enregistreur d'alarme HACCP	consultar - consult - consulter
Tropicalizado 43°C	Tropicalized to 43°C	Tropicalisé 43°C	consultar - consult - consulter
Respaldo inox	Stainless steel rear side	Soutien en inox	consultar - consult - consulter
230V 60hz / 115v 60hz	230V 60hz / 115v 60hz	230V 60hz / 115v 60hz	consultar - consult - consulter

Características técnicas y constructivas sujetas a variación sin previo aviso. / We reserve the right to change specifications without prior notice. / Sujet technique et la conception de modifications sans préavis.

BRG-135 2.588 € BCG-135 3.390 €	BRG-180 3.070 € BCG-180 3.981 €	BRG-225 3.641 €	BRG-270 4.103 €
BRG-135-V 2.982 € BCG-135-V 3.812 €	BRG-180-V 3.602 € BCG-180-V 4.605 €	BRG-225-V 4.321 €	BRG-270-V 4.980 €
BRG-135-F 2.842 €	BRG-180-F 3.338 €	BRG-225-F 3.820 €	BRG-270-F 4.451 €



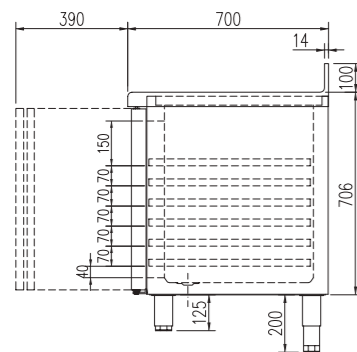

DETALLE PREINSTALACION  
detailed pre-installation  
détailée de pré-installation

Los modelos preinstalación NO incluyen valvulería, capilar y bandeja de evaporación automática  
The preinstallation models do not include valves, capillary and automatic evaporation tray  
Les modèles de préinstallation ne comprennent pas les vannes, capillaire et le plateau d'évaporation automatique

Ver características técnicas en página 250 / See technical data in page 250 / Voir caractéristiques techniques page 250

Modelo Model Modèle	Largo Length Longueur mm	Alto Height Hauteur mm	Fondo Depth Profondeur mm	Potencia Frig. Frig Power Puissance Frig. W	Capacidad Capacity Exposition L	Peso Neto Net Weight Poid Net Kg	Estantes Shelves Étagères	Pares de guías por puerta Sets of slides by door Kit de guides par porte	Voltaje Voltage Tension	Refrig. Coolant Frigorigène	Rango Range Gamme
BRGP / BRGPV-120	1045	850	700	300	255	75	2	2	230 V - 50 Hz	R-134a	-2°C+8°C
BRGP / BRGPV-170	1495	850	700	356	399	107	3	3	230 V - 50 Hz	R-134a	-2°C+8°C
BRGP / BRGPV-220	1945	850	700	485	543	139	4	4	230 V - 50 Hz	R-134a	-2°C+8°C
BRGP / BRGPV-270	2395	850	700	485	686	171	5	5	230 V - 50 Hz	R-134a	-2°C+8°C
BCGP / BCGPV-120	1045	850	700	353	255	75	2	2	230 V - 50 Hz	R-449A	-20°C-15°C
BCGP / BCGPV-170	1495	850	700	452	399	107	3	3	230 V - 50 Hz	R-449A	-20°C-15°C
BCGP / BCGPV-220	1945	850	700	610	543	139	4	4	230 V - 50 Hz	R-449A	-20°C-15°C



BRGP-220



BRGP-220-V

OPCIONES - OPTIONS - OPTIONS			
Parrilla suplemento	Supplement extra shelf	Grille additionnelle Supplement	21 € x ud
Parrilla adicional 530 X 325 GN1/1	530 X 325 GN1/1 extra shelf	Grille additionnelle 530 X 325 GN1/1	28 € x ud
Set adicional guías GN 1/1 340500006	GN 1/1 slides extra set	Kit supplémentaire de guides GN 1/1	30 € x set
Cajonera doble inox, auto-cierre	Double drawers set, self-closing	Tiroirs doubles inox, fermeture automatique	599 € x set
Cajonera triple inox, auto-cierre	Triple drawers set, self-closing	Tiroirs triple inox, fermeture automatique	790 € x set
Cerradura puerta inox	Solid door lock	Serrure à porte inox	25 € x ud
Cerradura puerta cristal	Glass door lock	Serrure à porte en verre	61 € x ud
Motor lado izquierdo	Left side engine	Moteur côté gauche	73 €
Encimera sin peto	No upstand worktop	Plan de travail sans panneau de protection	0 €
Set 4 ruedas	4 Castors set	Jeu 4 roulettes	98 € x set
Set 6 ruedas	6 Castors set	Jeu 6 roulettes	146 € x set
Evaporación automática	Automatic evaporation	Évaporation automatique	116 €
Registrador de alarmas HACCP	HACCP alarm recorder	Enregistreur d'alarme HACCP	consultar - consult - consulter
Tropicalizado 43°C	Tropicalized to 43°C	Tropicalisé 43°C	consultar - consult - consulter
Respaldo inox	Stainless steel rear side	Soutien en inox	consultar - consult - consulter
230V 60hz / 115v 60hz	230V 60hz / 115v 60hz	230V 60hz / 115v 60hz	consultar - consult - consulter

BRGP-120 <b>1.970 €</b>	BRGP-170 <b>2.372 €</b>	BRGP-220 <b>2.881 €</b>	BRGP-270 <b>3.338 €</b>
BCGP-120 <b>2.138 €</b>	BCGP-170 <b>2.560 €</b>	BCGP-220 <b>3.003 €</b>	
BRGP-120-V <b>2.290 €</b>	BRGP-170-V <b>2.825 €</b>	BRGP-220-V <b>3.466 €</b>	BRGP-270-V <b>4.071 €</b>
BCGP-120-V <b>2.573 €</b>	BCGP-170-V <b>3.208 €</b>	BCGP-220-V <b>3.850 €</b>	

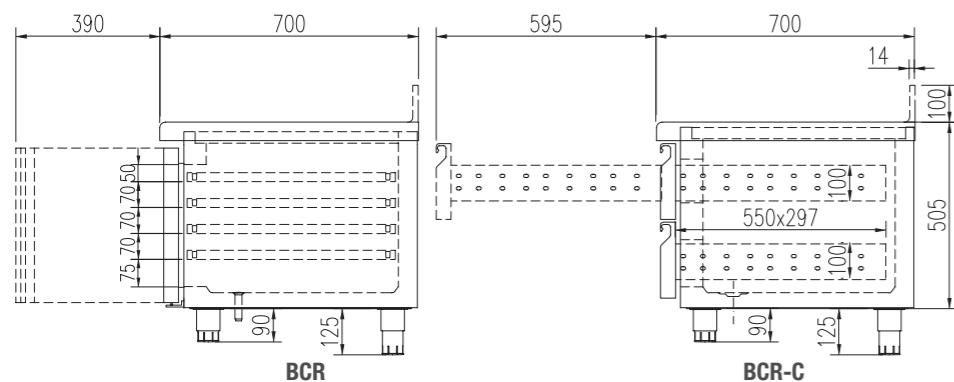

**CARACTERÍSTICAS TÉCNICAS**

• Cajoneras refrigeradas inox desmontables sobre guías inox telescópicas, sistema auto-cierre de serie

**TECHNICAL DATA**

• Stainless steel drawers with telescopic stainless steel slides for complete opening, self-closing system as standard

**CARACTÉRISTIQUES TECHNIQUES**

• Tiroirs réfrigérés démontables posés sur des rails télescopiques en inox ; système auto-bloquant de série

Ver características técnicas en página 250 / See technical data in page 250 / Voir caractéristiques techniques page 250

\* Gas opcional / \* Optional gas / \* Gaz optionnel

Modelo Model Modèle	Largo Length Longueur mm	Alto Height Hauteur mm	Fondo Depth Profondeur mm	Rango Range Gamme	Estantes Shelves Étagères	Pares de guías Sets of slides Kit de guides	Capacidad Capacity Exposition L	Voltaje Voltage Tension	Refrig. Coolant Frigo	Potencia Frig. Frig Power Puissance Frig. W	Consumo Nominal Nominal Consumption Consommation Nominale W	Rango Range Gamme	clase climate 2015/1094 EN16825 Rango Range Gamme
BCR-135	1345	600	700	-2°C +8°C	2	2	169	230 V - 50 Hz	R-290	414	270	B	4 (30°C 55%)
BCR-180	1795	600	700	-2°C +8°C	3	3	264	230 V - 50 Hz	R-290	502	337	B	4 (30°C 55%)
BCR-225	2245	600	700	-2°C +8°C	4	4	359	230 V - 50 Hz	R-290	845	340	C	5 (40°C 40%)
BCR-270	2695	600	700	-2°C +8°C	5	5	454	230 V - 50 Hz	R-290	845	355	C	5 (40°C 40%)
BCR-135-C	1345	600	700	-2°C +8°C	1	1	169	230 V - 50 Hz	R-290	502	218	B	5 (40°C 40%)
BCR-180-C	1795	600	700	-2°C +8°C	1	1	264	230 V - 50 Hz	R-290	502	218	C	5 (40°C 40%)
BCR-225-C	2245	600	700	-2°C +8°C	1	1	359	230 V - 50 Hz	R-290	845	340	D	5 (40°C 40%)





BCR-225



BCR-225-C

**OPCIONES · OPTIONS · OPTIONS**

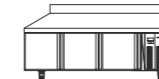
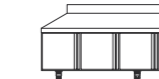
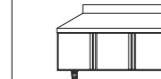
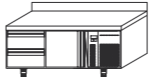
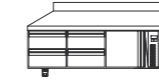
Parrilla adicional 530 X 325 GN1/1	530 X 325 GN1/1 extra shelf	Grille additionnelle 530 X 325 GN1/1	28 € x ud
Set adicional guías GN 1/1 340500006	GN 1/1 slides extra set	Kit supplémentaire de guides GN 1/1	30 € x set
Cerradura puerta inox	Solid door lock	Serrure à porte inox	25 € x ud
Cambio R-290 por R-134a	Change R-290 for R-134a	Changer le R-290 pour le R-134a	0 €
Cambio R-290 por R-452A	Change R-290 for R-452A	Changer le R-290 pour le R-452A	0 €
Encimera con peto	Worktop with upstand	Plan de travail sans panneau de protection	0 €
Set 4 ruedas	4 Castors set	Jeu 4 roulettes	98 € x set
Set 6 ruedas	6 Castors set	Jeu 6 roulettes	146 € x set
Motor lado izquierdo	Left side engine	Moteur côté gauche	73 €
Cambio 2 cajones 1/3 por uno 2/3	Change 2 1/3 drawers for one 2/3	Changer 2 tiroirs 1/3 pour un 2/3	Mismo precio - Same price - Même prix
Registrador de alarmas HACCP	HACCP alarm recorder	Enregistreur d'alarme HACCP	consultar - consult - consulter
Tropicalizado 43°C	Tropicalized to 43°C	Tropicalisé 43°C	consultar - consult - consulter
230V 60hz / 115v 60hz	230V 60hz / 115v 60hz	230V 60hz / 115v 60hz	consultar - consult - consulter

 BCR-135 <b>2.535 €</b>	 BCR-180 <b>3.110 €</b>	 BCR-225 <b>3.790 €</b>	 BCR-270 <b>4.785 €</b>
 BCR-135-C <b>2.775 €</b>	 BCR-180-C <b>3.590 €</b>	 BCR-225-C <b>4.510 €</b>	 BCR-270-C <b>5.745 €</b>

Características técnicas y constructivas sujetas a variación sin previo aviso. / We reserve the right to change specifications without prior notice. / Sujet technique et la conception de modifications sans préavis.



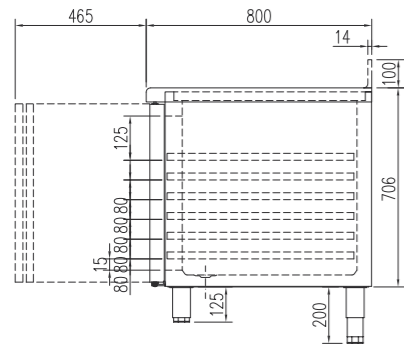

**BPR-250**

Ver características técnicas en página 250 / See technical data in page 250 / Voir caractéristiques techniques page 250

Modelo Model Modèle	Largo Length Longueur mm	Alto Height Hauteur mm	Fondo Depth Profondeur mm	Rango Range Gamme	Estantes Shelves Étagères	Pares de guías Sets of slides Kit de guides	Capacidad Capacity Exposition L	Voltaje Voltage Tension	Refrig. Coolant Frigorigène	Potencia Frig. Frig Power Puissance Frig. W	Consumo Nominal Nominal Consumption Consommation Nominale W	Rango Range Gamme	clase climate 2015/1094 EN16825 Rango Range Gamme
BPR-150	1495	850	800	-2°C +8°C	0	10	362	230 V - 50 Hz	R-290	502	235	A	5 (40°C 40%)
BPRV-150	1495	850	800	-2°C +8°C	0	10	362	230 V - 50 Hz	R-290	502	244	-	4 (30°C 55%)
BPR-200	2020	850	800	-2°C +8°C	0	15	562	230 V - 50 Hz	R-290	502	238	A	5 (40°C 40%)
BPRV-200	2020	850	800	-2°C +8°C	0	15	562	230 V - 50 Hz	R-290	502	251	-	4 (30°C 55%)
BPR-250	2545	850	800	-2°C +8°C	0	20	761	230 V - 50 Hz	R-290	845	370	B	5 (40°C 40%)
BPRV-250	2545	850	800	-2°C +8°C	0	20	761	230 V - 50 Hz	R-290	845	358	-	4 (30°C 55%)
BPC-150	1495	850	800	-20°C -15°C	0	10	362	230 V - 50 Hz	R-290	606	535	E	5 (40°C 40%)
BPCV-150	1495	850	800	-20°C -15°C	0	10	362	230 V - 50 Hz	R-290	606	544	-	4 (30°C 55%)
BPC-200	2020	850	800	-20°C -15°C	0	15	562	230 V - 50 Hz	R-290	606	556	E	4 (30°C 55%)
BPCV-200	2020	850	800	-20°C -15°C	0	15	562	230 V - 50 Hz	R-290	606	569	-	4 (30°C 55%)



**BPR-250-V**  
EJEMPLO DOTACIÓN EXTRA  
SAMPLE EXTRA EQUIPMENT  
EXEMPLE EQUIPEMENTS COMPLEMENTAIRES

EJEMPLO GUÍAS PASTELERAS  
EXAMPLE PASTRY GUIDES  
EXEMPLE DE GUIDES DE PÂTISSERIE

**OPCIONES · OPTIONS · OPTIONS**

Parrilla suplemento	Supplement extra shelf	Grille additionnelle Supplement	<b>28 € x ud</b>
Parrilla 600 x 400	600 x 400 shelf	Grille 600 x 400	<b>28 € x ud</b>
Set adicional guías 600 x 400 340500004	600 X 400 slides extra set	Kit supplémentaire de guides 600 x 400	<b>24 € x set</b>
Cerradura puerta inox	Solid door lock	Serrure à porte inox	<b>25 € x ud</b>
Cerradura puerta cristal	Glass door lock	Serrure à porte en verre	<b>61 € x ud</b>
Motor lado izquierdo	Left side engine	Moteur côté gauche	<b>73€</b>
Encimera con peto	Worktop with upstand	Plan de travail sans panneau de protection	<b>0 €</b>
Cambio R-290 por R-134a	Change R-290 for R-134a	Changer le R-290 pour le R-134a	<b>0 €</b>
Cambio R-290 por R-452A	Change R-290 for R-452A	Changer le R-290 pour le R-452A	<b>0 €</b>
Set 4 ruedas	4 Castors set	Jeu 4 roulettes	<b>98 € x set</b>
Set 6 ruedas	6 Castors set	Jeu 6 roulettes	<b>146 € x set</b>
Evaporación automática	Automatic evaporation	Évaporation automatique	<b>116 €</b>
Cajonera doble inox, auto-cierre	Double drawers set, self-closing	Tiroirs doubles inox, fermeture automatique	<b>742 €</b>
Exterior blanco o negro	Black or white exterior	Extérieur noir ou blanc	<b>consultar - consult-consulter</b>
Registrador de alarmas haccp	Haccp alarm recorder	Enregistreur d'alarme HACCP	<b>consultar - consult-consulter</b>
Tropicalizado 43°C	Tropicalized to 43°C	Tropicalisé 43°C	<b>consultar - consult-consulter</b>
Respaldo inox	Stainless steel rear side	Soutien en inox	<b>consultar - consult-consulter</b>
Encimera de granito	Granite worktop	Plan de travail de granit	<b>consultar - consult-consulter</b>
230V 60hz / 115v 60hz	230V 60hz / 115v 60hz	230V 60hz / 115v 60hz	<b>consultar - consult-consulter</b>

BPR-150 <b>2.881 €</b>	BPR-200 <b>3.445 €</b>	BPR-250 <b>4.156 €</b>
BPC-150 <b>3.573 €</b>	BPC-200 <b>4.183 €</b>	
BPR-150-V <b>3.294 €</b>	BPR-200-V <b>4.046 €</b>	BPR-250-V <b>4.901 €</b>
BPC-150-V <b>4.005 €</b>	BPC-200-V <b>4.806 €</b>	

Características técnicas y constructivas sujetas a variación sin previo aviso. / We reserve the right to change specifications without prior notice. / Sujet technique et la conception de modifications sans préavis.

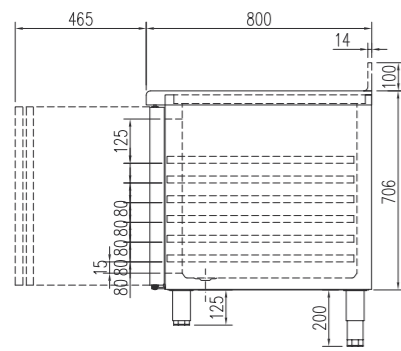

Ver características técnicas en página 250 / See technical data in page 250 / Voir caractéristiques techniques page 250

Modelo Model Modèle	Largo Length Longueur mm	Alto Height Hauteur mm	Fondo Depth Profondeur mm	Rango Range Gamme	Estantes Shelves Étagères	Pares de guías Sets of slides Kit de guides	Capacidad Capacity Exposition L	Voltaje Voltage Tension	Potencia Frig. Frig Power Puissance Frig. W
BPRP / BPRPV-120	1195	850	800	-2°C +8°C	0	9	255	230 V - 50 Hz	304
BPRP / BPRPV-170	1720	850	800	-2°C +8°C	0	14	399	230 V - 50 Hz	356
BPRP / BPRPV-220	2245	850	800	-2°C +8°C	0	19	543	230 V - 50 Hz	485
BPCP / BPCPV-120	1195	850	800	-20°C -15°C	0	9	255	230 V - 50 Hz	353
BPCP / BPCPV-170	1720	850	800	-20°C -15°C	0	14	399	230 V - 50 Hz	452
BPCP / BPCPV-220	2245	850	800	-20°C -15°C	0	19	543	230 V - 50 Hz	610



**BPRP-220**



**BPRP-220-V**  
 EJEMPLO DOTACIÓN EXTRA  
 SAMPLE EXTRA EQUIPMENT  
 EXEMPLE EQUIPEMENTS COMPLEMENTAIRES

**OPCIONES · OPTIONS · OPTIONS**

Parrilla suplemento	Supplement extra shelf	Grille additionnelle Supplement	<b>28 € x ud</b>
Parrilla 600 x 400	600 x 400 shelf	Grille 600 x 400	<b>28 € x ud</b>
Set adicional guías 600 x 400 340500004	600 X 400 slides extra set	Kit supplémentaire de guides 600 x 400	<b>24 € x set</b>
Cerradura puerta inox	Solid door lock	Serrure à porte inox	<b>25 € x ud</b>
Cerradura puerta cristal	Glass door lock	Serrure à porte en verre	<b>61 € x ud</b>
Motor lado izquierdo	Left side engine	Moteur côté gauche	<b>73€</b>
Encimera sin peto	Worktop without upstand	Plan de travail sans panneau de protection	<b>0 €</b>
Set 4 ruedas	4 Castors set	Jeu 4 roulettes	<b>98 €</b>
Set 6 ruedas	6 Castors set	Jeu 6 roulettes	<b>146 €</b>
Evaporación automática	Automatic evaporation	Évaporation automatique	<b>180 €</b>
Registrador de alarmas haccp	Haccp alarm recorder	Enregistreur d'alarme HACCP	<b>consultar - consult-consulter</b>
Tropicalizado 43°C	Tropicalized to 43°C	Tropicalisé 43°C	<b>consultar - consult-consulter</b>
Respaldo inox	Stainless steel rear side	Soutien en inox	<b>consultar - consult-consulter</b>
230V 60hz / 115v 60hz	230V 60hz / 115v 60hz	230V 60hz / 115v 60hz	<b>consultar - consult-consulter</b>

BPRP-120 <b>2.157 €</b>	BPRP-170 <b>2.715 €</b>	BPRP-220 <b>3.279 €</b>
BPCP-120 <b>2.365 €</b>	BPCP-170 <b>2.985 €</b>	
BPRP-120-V <b>2.365 €</b>	BPRP-170-V <b>2.985 €</b>	BPRP-220-V <b>3.353 €</b>
BPCP-120-V <b>2.819 €</b>	BPCP-170-V <b>3.644 €</b>	

Características técnicas y constructivas sujetas a variación sin previo aviso. / We reserve the right to change specifications without prior notice. / Sujet technique et la conception de modifications sans préavis.

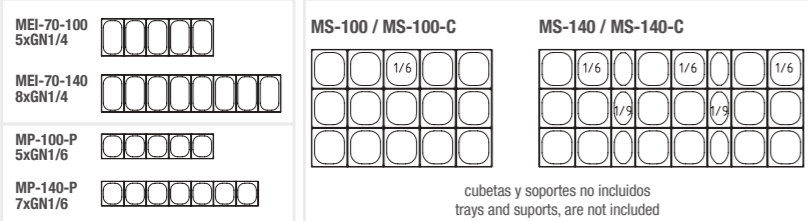
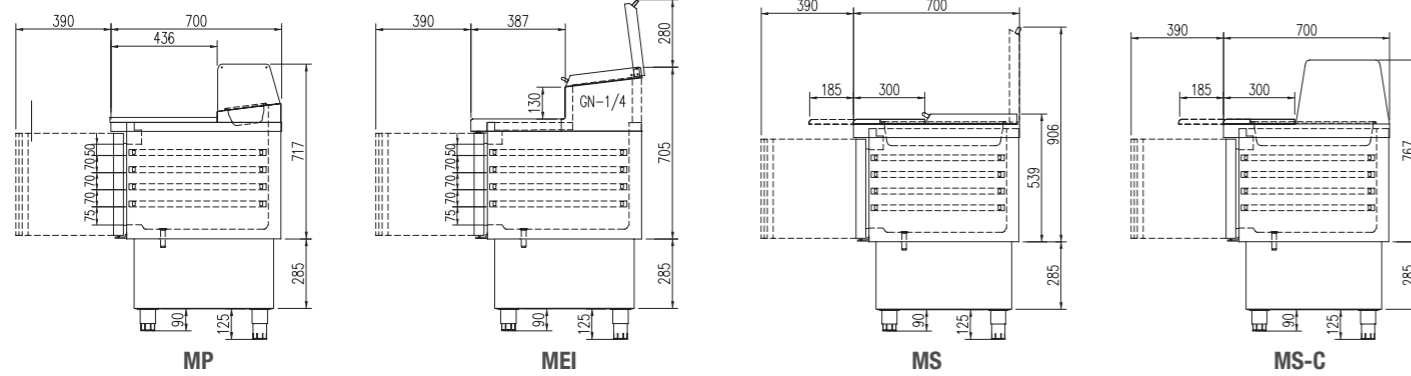

DETALLE MS

evaporador central



**MP-140-P**

CON CAJONES OPCIONALES  
OPTIONAL DRAWERS  
TIROIR EN OPTION



**MEI-70-100**



**MS-100-C**



**MS-100**

CARACTERÍSTICAS TÉCNICAS	TECHNICAL DATA	CARACTÉRISTIQUES TECHNIQUES
<ul style="list-style-type: none"> <li>MP encimera granito, cúpula acristalada sobre alojamientos GN 1/6-100</li> <li>MEI70 encimera inox, cubierta inox abatible sobre expositor ingredientes GN 1/4-150</li> <li>MS cúpula acristalada sobre alojamiento cubetas</li> <li>MS-C cubierta inox abatible sobre alojamiento cubetas</li> <li>Estantes interiores GN 1/1</li> </ul>	<ul style="list-style-type: none"> <li>MP granite working area and glass cover, GN 1/6-100 capacity</li> <li>MEI70 stainless steel worktop, topping unit with hinged lid, GN 1/4-150 capacity</li> <li>MS glass cover</li> <li>MS-C hinged lid</li> <li>Interior shelf GN 1/1</li> </ul>	<ul style="list-style-type: none"> <li>MP Plan de travail en granit, vitrine en verre, capa-cité GN 1/6-100</li> <li>MEI70 plan de travail en inox, couvercle en inox, rabattable sur présentoir à ingrédients GN ¼-150</li> <li>MS vitrine en verre</li> <li>MS-C couvercle en inox</li> <li>Intérieur grille GN 1/1</li> </ul>

Ver características técnicas en página 250 / See technical data in page 250 / Voir caractéristiques techniques page 250

Modelo Model Modèle	Largo Length Longueur mm	Alto Height Hauteur mm	Fondo Depth Profondeur mm	Rango Range Gamme	Perfiles GN GN Supports Profil GN	Estantes Shelves Étagères	Pares de guías Sets of slides Kit de guides	Capacidad Capacity Exposition L	Voltaje Voltage Tension	Refrig. Coolant Frigorigène	Potencia Frig. Frig Power Puissance Frig. W	Consumo Nominal Nominal Consumption Consommation Nominale W
MEI-70-100	925	890	700	0°C +8°C	-	2	2	169	230 V - 50 Hz	R-290	502	764
MEI-70-140	1375	890	700	0°C +8°C	-	3	3	264	230 V - 50 Hz	R-290	1004	614
MP-100-P	925	890	700	0°C +8°C	-	2	2	169	230 V - 50 Hz	R-290	502	764
MP-140-P	1375	890	700	0°C +8°C	-	3	3	264	230 V - 50 Hz	R-290	1004	614
MS-100	925	890	700	0°C +8°C	4	2	2	169	230 V - 50 Hz	R-290	502	764
MS-140	1375	890	700	0°C +8°C	7	3	3	264	230 V - 50 Hz	R-290	1004	614
MS-100-C	925	890	700	0°C +8°C	4	2	2	169	230 V - 50 Hz	R-290	502	764
MS-140-C	1375	890	700	0°C +8°C	7	3	3	264	230 V - 50 Hz	R-290	1004	614

OPCIONES · OPTIONS · OPTIONS			
Parrilla adicional 530 X 325 GN1/1	530 X 325 GN1/1 extra shelf	Grille additionnelle 530 X 325 GN1/1	28 € x ud
Set adicional guías GN 1/1 340500006	GN 1/1 slides extra set	Kit supplémentaire de guides GN 1/1	30 € x set
Cajonera doble inox, auto-cierre	Double drawers set, self-closing	Tiroirs doubles inox, fermeture automatique	537 € x set
Cerradura puerta inox	Solid door lock	Serrure à porte inox	25 €
Set 4 ruedas	4 Castors set	Jeu 4 roulettes	98 € x set
Registrador de alarmas haccp	Haccp alarm recorder	Enregistreur d'alarme HACCP	consultar - consult - consulter
230V 60hz / 115v 60hz	230V 60hz / 115v 60hz	230v 60Hz / 115v 60Hz	consultar - consult - consulter
Cambio R-290 por R-134a	Change R-290 for R-134a	Changer le R-290 pour le R-134a	0 €

Encimeras, alojamientos para cubetas y cubiertas, se pueden fabricar a medida.  
Worktops, containers fits and covers, can be customized.  
Les plans de travail, les récipients pour des bacs et couvercles, peuvent être personnalisés

Características técnicas y constructivas sujetas a variación sin previo aviso. / We reserve the right to change specifications without prior notice. / Sujet technique et la conception de modifications sans préavis.

MP-100-P <b>2.412 €</b>	MEI-70-100 <b>2.381 €</b>	MS-100 <b>2.283 €</b>	MS-100-C <b>2.252 €</b>
MP-140-P <b>2.911 €</b>	MEI-70-140 <b>2.881 €</b>	MS-140 <b>2.733 €</b>	MS-140-C <b>2.714 €</b>

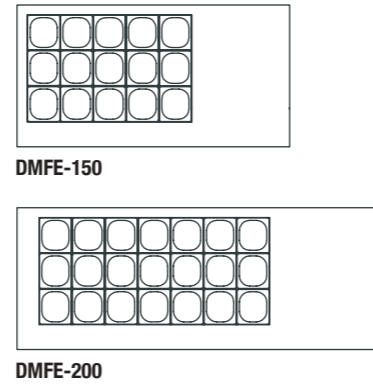
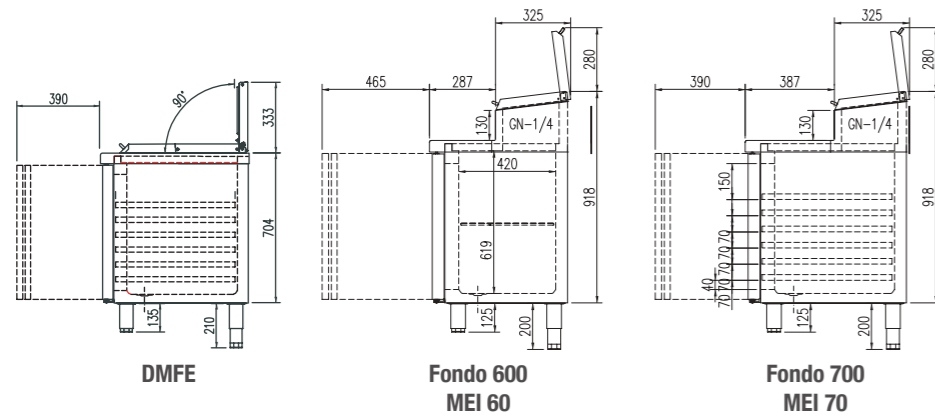

CARACTERÍSTICAS TÉCNICAS	TECHNICAL DATA	CARACTÉRISTIQUES TECHNIQUES
<ul style="list-style-type: none"> <li>DMFE: Encimera inox con capacidad cubetas GN (ver detalle) y cubierta inox abatible y plegable</li> <li>MEI Encimera inox con expositor de ingredientes integrado y cubierta inox abatible</li> <li>Expositor ingredientes GN 1/4-150</li> <li>MEI60 estantes interiores de alambre en acero plastificado, regulables en altura, sobre apoyos inox</li> <li>MEI70 estantes interiores GN 1/1 de alambre en acero plastificado, sobre guías de acero inox regulables en altura</li> </ul>	<ul style="list-style-type: none"> <li>DMFE: AISI-304 stainless steel worktop, capacity for GN containers (see detail) with hinged stainless steel lid</li> <li>MEI AISI-30418/10 stainless steel worktop, raised topping well with hinged lid</li> <li>GN 1/4-150 topping unit</li> <li>MEI60 shelves made of plasticized steel wire, height adjustable</li> <li>MEI70 GN 1/1 shelves made of plasticized steel wire, height adjustable</li> </ul>	<ul style="list-style-type: none"> <li>Plan de travail en inox avec capacité de bac GN (voir détail) et couvercle inox rabattable et repliable</li> <li>MEI Plan de travail en inox avec présentoir à ingrédients intégré et couvercle en inox rabattable</li> <li>Présentoir à ingrédients GN ¼-150</li> <li>MFEI60 étagères intérieures de fil de fer plastifié, réglables en hauteur sur des appuis inox</li> <li>MFEI70 étagères intérieures GN 1/1 de fil de fer plastifié, réglables en hauteur, sur des glisses d'acier inox réglables en hauteur</li> </ul>

Ver características técnicas en página 250 / See technical data in page 250 / Voir caractéristiques techniques page 250

\* Gas opcional / \* Optional gas / \* Gaz optionnel

Modelo / Model / Modèle	Largo / Length / Longueur mm	Alto / Height / Hauteur mm	Fondo / Depth / Profondeur mm	Rango / Range / Gamme	Estantes / Shelves / Étagères	Pares de guías / Sets of slides / Kit de guides	Capacidad / Capacity / Exposition L	Perfiles GN / Profile GN / Profils GN 1/6	Capacidad GN / Capacity GN / Exposition 1/4	Voltaje / Voltage / Tension	Refrig. / Coolant / Frigorigène	Potencia Frig. / Frig Power / Puissance Frig. W	Consumo Nominal / Nominal Consumption / Consommation Nominale W
DMFE-150	1345	850	700	0°C +8°C	2	2	255	4		230 V - 50 Hz	R-290	502	490
DMFE-200	1795	850	700	0°C +8°C	3	3	399	6		230 V - 50 Hz	R-290	845	794
MEI60-150	1495	850	600	0°C +8°C	2	0	245		8	230 V - 50 Hz	R-290	502	264
MEI60-200	2020	850	600	0°C +8°C	3	0	380		12	230 V - 50 Hz	R-290	820	614
MEI70-135	1345	850	700	0°C +8°C	2	2	255		8	230 V - 50 Hz	R-290	502	264
MEI70-180	1795	850	700	0°C +8°C	3	3	399		10	230 V - 50 Hz	R-290	820	614
MEI70-225	2245	850	700	0°C +8°C	4	4	543		13	230 V - 50 Hz	R-290	820	614
MEI70-270	2695	850	700	0°C +8°C	5	5	686		16	230 V - 50 Hz	R-290	820	670

OPCIONES · OPTIONS · OPTIONS			
Parrilla adicional 530 X 325 GN1/1	530 X 325 GN1/1 extra shelf	Grille additionnelle 530 X 325 GN1/1	28 € x ud
Set adicional guías GN 1/1 340500006	GN 1/1 slides extra set	Kit supplémentaire de guides GN 1/1	30 € x set
Cajonera doble inox, auto-cierre	Double drawers set, self-closing	Tiroirs doubles, fermeture automatique	599 € x set
Cajonera triple inox, auto-cierre	Triple drawers set, self-closing	Tiroirs triples, fermeture automatique	790€ x set
Cerradura puerta inox	Solid door lock	Serrure à porte inox	25 € x ud
Motor lado izquierdo	Left side engine	Moteur côté gauche	73 €
Set 4 ruedas	4 Castors set	Jeu 4 roulettes	98 € x set
Set 6 ruedas	6 Castors set	Jeu 6 roulettes	146 € x set
Registrador de alarmas HACCP	HACCP alarm recorder	Enregistreur d'alarme HACCP	consultar - consult - consulter
Respaldo inox	Stainless steel rear side	Soutien en inox	consultar - consult - consulter
Encimera de granito	Granite worktop	Plan de travail en granit	consultar - consult - consulter
230v 60hz / 115v 60hz	230v 60hz / 115v 60hz	230v 60Hz / 115v 60Hz	consultar - consult - consulter

Encimeras, alojamientos para cubetas y cubiertas, se pueden fabricar a medida.  
Worktops, containers fits and covers, can be customized.  
Les plans de travail, les récipients pour des bacs et couvercles, peuvent être personnalisés

Características técnicas y constructivas sujetas a variación sin previo aviso. / We reserve the right to change specifications without prior notice. / Sujet technique et la conception de modifications sans préavis.



DMFE-200



MEI70-180

DMFE-150 3.132 €	DMFE-200 3.755 €
MEI70-135 3.258 €	MEI70-180 3.876 €
	MEI70-225 4.451 €





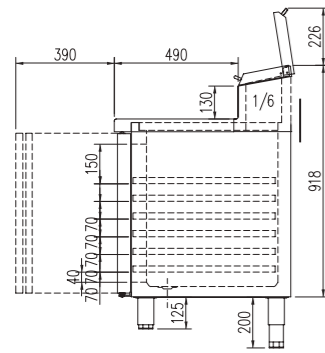

MEI-70

MEI-70-180-1/6  
8xGN1/6



MEI-70-225-1/6  
12xGN1/6



MEI-70-270-1/6  
14xGN1/6



CARACTERÍSTICAS TÉCNICAS	TECHNICAL DATA	CARACTÉRISTIQUES TECHNIQUES
<ul style="list-style-type: none"> <li>Encimera inox con expositor de ingredientes integrado y cubierta inox abatible</li> <li>Expositor ingredientes GN 1/6-150</li> <li>Modelo ST, sin tapa inox abatible sobre el alojamiento cubetas.</li> </ul>	<ul style="list-style-type: none"> <li>ANSI-30418/10 stainless steel worktop, raised topping well with hinged lid</li> <li>GN 1/6-150 topping unit</li> <li>ST model, no lids</li> </ul>	<ul style="list-style-type: none"> <li>Plan de travail en inox avec présentoir à ingrédients intégré et couvercle en inox rabattable</li> <li>Présentoir à ingrédients GN 1/6-150</li> <li>Modèle ST, sans couvercle en inox rabattable sur le récipient des bacs</li> </ul>

Ver características técnicas en página 250 / See technical data in page 250 / Voir caractéristiques techniques page 250

\* Gas opcional / \* Optional gas / \* Gaz optionnel

Modelo Model Modèle	Largo Length Longueur mm	Alto Height Hauteur mm	Fondo Depth Profondeur mm	Rango Range Gamme	Estantes Shelves Étagères	Pares de guías Sets of slides Kit de guides	Capacidad Capacity Exposition L	Capacidad GN Capacity GN Exposition GN 1/6	Voltaje Voltage Tension	Refrig. Coolant Frigorigène	Potencia Frig. Frig Power Puissance Frig. W	Consumo Nominal Nominal Consumption Consommation Nominale W
MEI-70-180	1795	850	700	0°C +8°C	3	3	399	10	230 V - 50 Hz	R-290	1004	614
MEI-70-225	2245	850	700	0°C +8°C	4	4	543	13	230 V - 50 Hz	R-290	1004	614
MEI-70-270	2695	850	700	0°C +8°C	5	5	686	14	230 V - 50 Hz	R-290	1004	670

OPCIONES · OPTIONS · OPTIONS			
Parrilla adicional 530 X 325 GN1/1	530 X 325 GN1/1 extra shelf	Grille additionnelle 530 X 325 GN1/1	28 € x ud
Cerradura puerta inox	Solid door lock	Serrure à porte inox	25 € x ud
Motor lado izquierdo	Left side engine	Moteur côté gauche	73 €
Set 4 ruedas	4 Castors set	Jeu 4 roulettes	98 € x set
Set 6 ruedas	6 Castors set	Jeu 6 roulettes	146 € x set
Cajonera doble inox, auto-cierre	Double drawers set, self-closing	Tiroirs doubles inox, fermeture automatique	599 € x set
Cajonera triple inox, auto-cierre	Triple drawers set, self-closing	Tiroirs triple inox, fermeture automatique	790 € x set
Registador de alarmas HACCP	HACCP alarm recorder	Enregistreur d'alarme HACCP	consultar - consult - consulter
Encimera de granito	Granite worktop	Plan de travail en granit	consultar - consult - consulter
Respaldo inox	Stainless steel rear side	Soutien en inox	consultar - consult - consulter
230V 60hz / 115v 60hz	230V 60hz / 115v 60hz	230v 60Hz / 115v 60Hz	consultar - consult - consulter

Encimeras, alojamientos para cubetas y cubiertas, se pueden fabricar a medida.  
Worktops, containers fits and covers, can be customized.  
Les plans de travail, les récipients pour des bacs et couvercles, peuvent être personnalisés



MEI-70-225-1/6

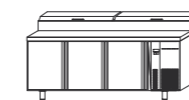

MEI-70-180-1/6 3.876 €

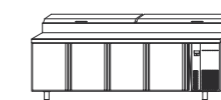

MEI-70-225-1/6 4.571 €

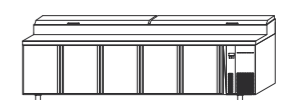

MEI-70-270-1/6 5.690 €

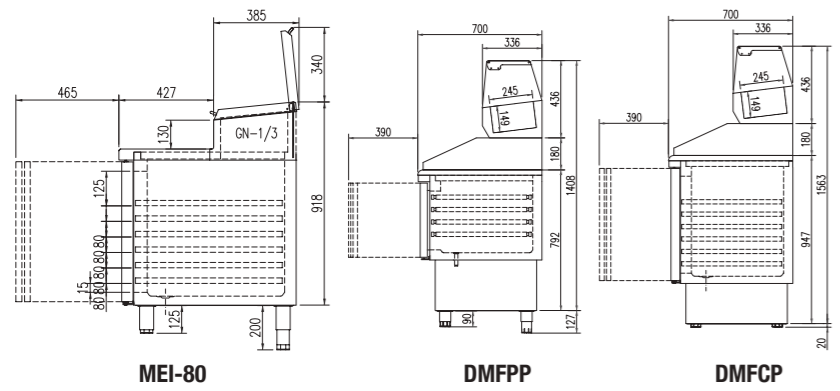

Expositor topping con iluminación LED  
 LED lighting topping unit  
 Expositant en tête avec éclairage LED



Encimera granito opcional  
 Optional granite worktop  
 Comptoir de granit en option



Bandeja y parrilla de trabajo, opcionales  
 with working grills and trays, optional  
 plateau et grille de travail, en option



Prof. máxima: 65 mm.  
 Max depth: 65 mm.  
 Prof. maximale: 65 mm.

CARACTERÍSTICAS TÉCNICAS	TECHNICAL DATA	CARACTÉRISTIQUES TECHNIQUES
<ul style="list-style-type: none"> <li>DMF Encimera de granito, con peto trasero y laterales de 180 mm</li> <li>DMF Expositor de ingredientes independiente, capacidad GN 1/4, incluido</li> <li>MEI-80 Encimera inox con expositor de ingredientes integrado y cubierta inox abatible</li> <li>MEI-80 Expositor ingredientes GN 1/3-150</li> <li>MEI-80 Estantes interiores 60x40 de alambre en acero plastificado, sobre guías de acero inox regulables en altura</li> <li>MEI-80 OPCIONAL: parrilla de trabajo 525x400 con bandeja recogedora</li> </ul>	<ul style="list-style-type: none"> <li>DMF Granite working surface with 180 mm up stands</li> <li>DMF GN 1/4 topping unit, included</li> <li>MEI-80 AISI-30418/10 stainless steel worktop, raised topping well with hinged lid</li> <li>MEI-80 GN 1/3-150 topping unit</li> <li>MEI-80 Capacity for 60x40 shelves, containers or trays by stainless steel slides, height adjustable</li> <li>MEI-80 OPTIONAL: 525x400 working grill with drip pan</li> </ul>	<ul style="list-style-type: none"> <li>DMF Plan de travail en granit, avec pente arrière et côtés de 180 mm</li> <li>DMF Expositant les ingrédients séparés, GN 1/4 capacités, inclus</li> <li>MEI-80 Plan de travail en inox avec présentoir à ingrédients intégré et couvercle en inox rabattable</li> <li>MEI-80 Présentoir à ingrédients GN 1/3-150</li> <li>MEI-80 Étagères intérieures 60x40 de fil de fer plastifié, sur des glisses d'acier inox réglables en hauteur</li> <li>MEI-80 EN OPTION : grille de travail 525x400 avec plateau qui recueille</li> </ul>

Ver características técnicas en página 250 / See technical data in page 250 / Voir caractéristiques techniques page 250

\* Gas opcional / \* Optional gas / \* Gaz optionnel

Modelo / Model / Modèle	Largo / Length / Longueur mm	Alto / Height / Hauteur mm	Fondo / Depth / Profondeur mm	Rango / Range / Gamme	Estantes / Shelves / Étagères	Pares de guías / Sets of slides / Kit de guides	Capacidad / Capacity / Exposition L	Capacidad GN / Capacity GN / Exposition GN	Voltaje / Voltage / Tension	Refrig. / Coolant / Frigorigène	Potencia Frig. / Frig Power / Puissance Frig. W	Consumo Nominal / Nominal Consumption / Consommation Nominale W
MEI-80-150	1495	850	800	0°C +8°C	2	2	362	GN 1/4: 8 uds	230 V - 50 Hz	R-290	502	764
MEI-80-200	2020	850	800	0°C +8°C	3	3	562	GN 1/4: 10 uds	230 V - 50 Hz	R-290	1004	614
DMFPP-140	1370	890	700	0°C +8°C	3	3	264	GN 1/4: 5 uds	230 V - 50 Hz	R-290	1004	614
DMFCP-140	1370	970	700	0°C +8°C	3	3	399	GN 1/4: 5 uds	230 V - 50 Hz	R-290	1004	614

OPCIONES · OPTIONS · OPTIONS			
Parrilla adicional 530 X 325 GN1/1	530 X 325 GN1/1 extra shelf	Grille additionnelle 530 X 325 GN1/1	28 € x ud
Set adicional guías GN 1/1	GN 1/1 slides extra set	Jeu supplémentaire glisses GN 1/1	30 € x set
Cajonera doble inox, auto-cierre	Double drawers set, self-closing	Tiroirs doubles en inox, fermeture automatique	599 € x set
Cajonera triple inox, auto-cierre	Triple drawers set, self-closing	Tiroirs triples en inox, fermeture automatique	799 € x set
Cerradura puerta inox	solid door lock	Serrure à porte inox	25 € x ud
Set 4 ruedas	4 castors set	Jeu 4 roulettes	98 € x set
Parrilla + bandeja trabajo 500x400	Grill + tray 500x400	Grille + plateau de travail 500x400	187 € x ud
Motor lado izquierdo	Left side engine	Moteur côté gauche	73 €
Set 6 ruedas	6 Castors set	Jeu 6 roulettes	146 € x set
Registrador de alarmas HACCP	HACCP alarm recorder	Enregistreur d'alarme HACCP	consultar - consult - consulter
Encimera de granito	Granite worktop	Plan de travail en granit	consultar - consult- consulter
Respaldo inox	Stainless steel rear side	Soutien en inox	consultar - consult- consulter
230v 60Hz / 115v 60Hz	230v 60Hz / 115v 60Hz	230v 60Hz / 115v 60Hz	consultar - consult - consulter

Encimeras, alojamientos para cubetas y cubiertas, se pueden fabricar a medida.  
 Worktops, containers fits and covers, can be customized.  
 Les plans de travail, les récipients pour des bacs et couvercles, peuvent être personnalisés

Características técnicas y constructivas sujetas a variación sin previo aviso. / We reserve the right to change specifications without prior notice. / Sujet technique et la conception de modifications sans préavis.



DMFPP-140



DMFCP-140

<p>MEI-80-150 <b>3.714 €</b></p>	<p>MEI-80-200 <b>4.290 €</b></p>
<p>DMFPP-140 <b>3.820 €</b></p>	<p>DMFCP-140 <b>4.518 €</b></p>

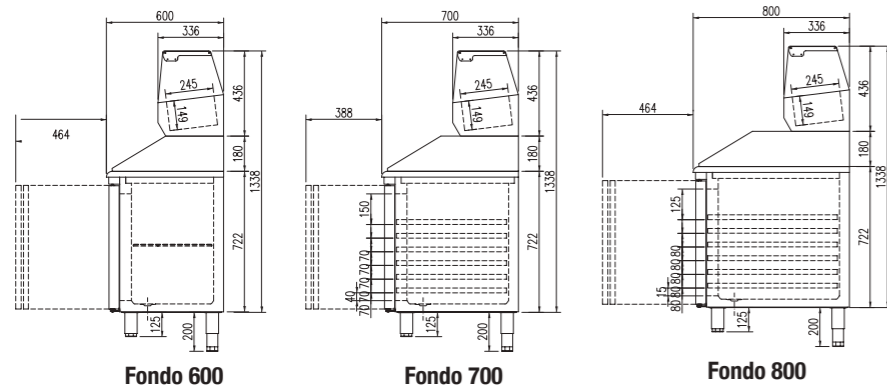

Detalle encimera granito  
granite countertop detail  
Détail de comptoir en granit



MP-70-225-R



MP-60-150-R

CARACTERÍSTICAS TÉCNICAS	TECHNICAL DATA	CARACTÉRISTIQUES TECHNIQUES
<ul style="list-style-type: none"> <li>Encimera de granito, con peto trasero y laterales de 180 mm</li> <li>Expositor de ingredientes independiente, capacidad GN 1/4, incluido</li> <li>MP60 estantes interiores de alambre en acero plastificado, regulables en altura, sobre apoyos inox</li> <li>MP70 estantes interiores GN 1/1 de alambre en acero plastificado, sobre guías de acero inox regulables en altura</li> </ul>	<ul style="list-style-type: none"> <li>Granite working surface with 180 mm up stands</li> <li>GN 1/4 topping unit, included</li> <li>MR60 shelves made of plasticized steel wire, height adjustable</li> <li>MR70 shelves made of plasticized steel wire, height adjustable</li> </ul>	<ul style="list-style-type: none"> <li>Plan de travail en granit, avec pente arrière et côtés de 180 mm</li> <li>Évaporation automatique des eaux de dégivrage</li> <li>MR60 étagères intérieures avec enfil de fer plasti-fi é, réglables en hauteur sur appuis en inox</li> <li>MR70 étagères intérieures GN 1/1 en fil de fer plasti-fi é, sur des glisses en acier inox réglables en hauteur</li> </ul>

Ver características técnicas en página 250 / See technical data in page 250 / Voir caractéristiques techniques page 250

\* Gas opcional / \* Optional gas / \* Gaz optionnel

Modelo Model Modèle	Largo Length Longueur mm	Alto Height Hauteur mm	Fondo Depth Profondeur mm	Rango Range Gamme	Estantes Shelves Étagères	Pares de guías Sets of slides Kit de guides	Cajas Containers Boîtes 40x60	Capacidad Capacity Exposition L	Capacidad GN Capacity GN Exposition GN 1/4	Voltaje Voltage Tension	Refrig. Coolant Frigorigène	Potencia Frig. Frig Power Puissance Frig. W	Consumo Nominal Nominal Consumption Consommation Nominale W
MP-60-150-R	1495	850	600	0°C +8°C	2	0	0	245	6	230 V - 50 Hz	R-290	502	235
MP-60-200-R	2020	850	600	0°C +8°C	3	0	0	380	9	230 V - 50 Hz	R-290	502	238
MP-60-250-R	2545	850	600	0°C +8°C	4	0	0	516	12	230 V - 50 Hz	R-290	845	355
MP-70-135-R	1345	850	700	0°C +8°C	2	2	0	255	5	230 V - 50 Hz	R-290	502	235
MP-70-180-R	1795	850	700	0°C +8°C	3	3	0	399	8	230 V - 50 Hz	R-290	502	238
MP-70-225-R	2245	850	700	0°C +8°C	4	4	0	543	10	230 V - 50 Hz	R-290	845	355
MP-80-150-R	1495	850	800	0°C +8°C	0	8	3	362	6	230 V - 50 Hz	R-290	502	235
MP-80-200-R	2020	850	800	0°C +8°C	0	13	3	562	9	230 V - 50 Hz	R-290	502	238
MP-80-250-R	2545	850	800	0°C +8°C	0	18	3	761	12	230 V - 50 Hz	R-290	845	355

OPCIONES PARA MP - OPTIONS FOR MP - OPTIONS POUR MP			
Cerradura puerta inox	Solid door lock	Serrure à porte inox	25 € x ud
Motor lado izquierdo	Left side engine	Moteur côté gauche	73 €
Set 4 ruedas	4 Castors set	Jeu 4 roulettes	98 € x set
Set 6 ruedas	6 Castors set	Jeu 6 roulettes	146 € x set
Registrador de alarmas haccp	Haccp alarm recorder	Enregistreur d'alarme HACCP	consultar - consult- consulter
Respaldo inox	Stainless steel rear side	Soutien en inox	consultar - consult- consulter
230V 60hz / 115v 60hz	230V 60hz / 115v 60hz	230v 60Hz / 115v 60Hz	consultar - consult- consulter

	MP-60-150-R <b>3.808 €</b>		MP-60-200-R <b>4.384 €</b>		MP-60-250-R <b>5.135 €</b>
	MP-70-135-R <b>4.010 €</b>		MP-70-180-R <b>4.739 €</b>		MP-70-225-R <b>5.410 €</b>
	MP-80-150-R <b>4.437 €</b>		MP-80-200-R <b>5.350 €</b>		MP-80-250-R <b>5.732 €</b>

Características técnicas y constructivas sujetas a variación sin previo aviso. / We reserve the right to change specifications without prior notice. / Sujet technique et la conception de modifications sans préavis.

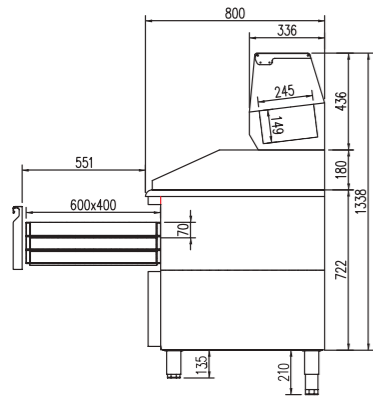

Detalle cubetas GN (No incluidas)  
Buckets detail GN (Not included)  
Détail cuvettes GN (Non inclus)



Detalle apertura cajon  
Opening detail drawer  
Détail l'ouverture du tiroir



**MP-80-160-R**

**CARACTERÍSTICAS TÉCNICAS**

- Encimera de granito, con peto trasero y laterales de 180 mm
- Expositor de ingredientes incluido, capacidad cubetas GN 1/4, (No incluidas)
- Interior con guías de acero inox, regulables en altura para parrillas, bandejas o contenedores 60x40x7 (4 en dotación)
- Cajon neutro con 3 cajas plasticas 60x40x7 en dotación

**TECHNICAL DATA**

- Granite working surface with 180 mm up stands
- Ingredient display included, capacity GN 1/4 cuvettes, (Not included)
- Inner with stainless steel guides, adjustable in height for grills, trays or containers 60x40x7 (4 supplied)
- Neutral drawer with 3 plastic boxes 60x40x7 in endowment

**CARACTÉRISTIQUES TECHNIQUES**

- Plan de travail en granit, avec pente arrière et côtés de 180 mm
- Ingrédients exposants inclus Capacité 1/4 bacs GN (non inclus)
- Intérieur de guidage en acier inoxydable, des supports réglables en hauteur, des plateaux ou récipients 60x40x7 (4 fournis)
- Cajon neutre avec 3 boîtes en plastique fourni 60x40x7

Ver características técnicas en página 250 / See technical data in page 250 / Voir caractéristiques techniques page 250

\* Gas opcional / \* Optional gas / \* Gaz optionnel

Modelo Model Modèle	Largo Length Longueur mm	Alto Height Hauteur mm	Fondo Depth Profondeur mm	Rango Range Gamme	Estantes Shelves Étagères	Pares de guías Sets of slides Kit de guides	Cajas Refrigeradas Refrigerated boxes Boîtes réfrigéré	Cajas Neutras Neutral boxes Boîtes neutres	Capacidad Capacity Exposition L	Voltaje Voltage Tension	Refrig. Coolant Frigorigène	Potencia Frig. Frig Power Puissance Frig. W	Consumo Nominal Nominal Consumption Consommation Nominale W
MP-80-160-R	1565	850	800	0°C +8°C	0	8	3	3	362	230 V - 50 Hz	R-290	502	235
MP-80-210-R	2090	850	800	0°C +8°C	0	13	3	3	562	230 V - 50 Hz	R-290	502	238
MP-80-265-R	2615	850	800	0°C +8°C	0	16	3	3	761	230 V - 50 Hz	R-290	845	355

**OPCIONES - OPTIONS - OPTIONS**

Cerradura puerta inox	Solid door lock	Serrure à porte inox	28 € x ud
Motor lado izquierdo	Left side engine	Moteur côté gauche	73 €
Set 4 ruedas	4 Castors set	Jeu 4 roulettes	98 € x set
Set 6 ruedas	6 Castors set	Jeu 6 roulettes	146 € x set
Parrilla 60x40	60x40 shelf	Grille 60x60	28 €
Cajón plástico 60x40x7	60x40x7 plastic container	tiroir en matière plastique 60x40x7	35 € x ud
Cajón plástico 60x40x12	60x40x12 plastic container	tiroir en matière plastique 60x40x12	45 € x ud
Registrador de alarmas haccp	Haccp alarm recorder	Enregistreur d'alarme HACCP	consultar - consult- consulter
Respaldo inox	Stainless steel rear side	Soutien en inox	consultar - consult- consulter
230V 60hz / 115v 60hz	230V 60hz / 115v 60hz	230v 60Hz / 115v 60Hz	consultar - consult- consulter

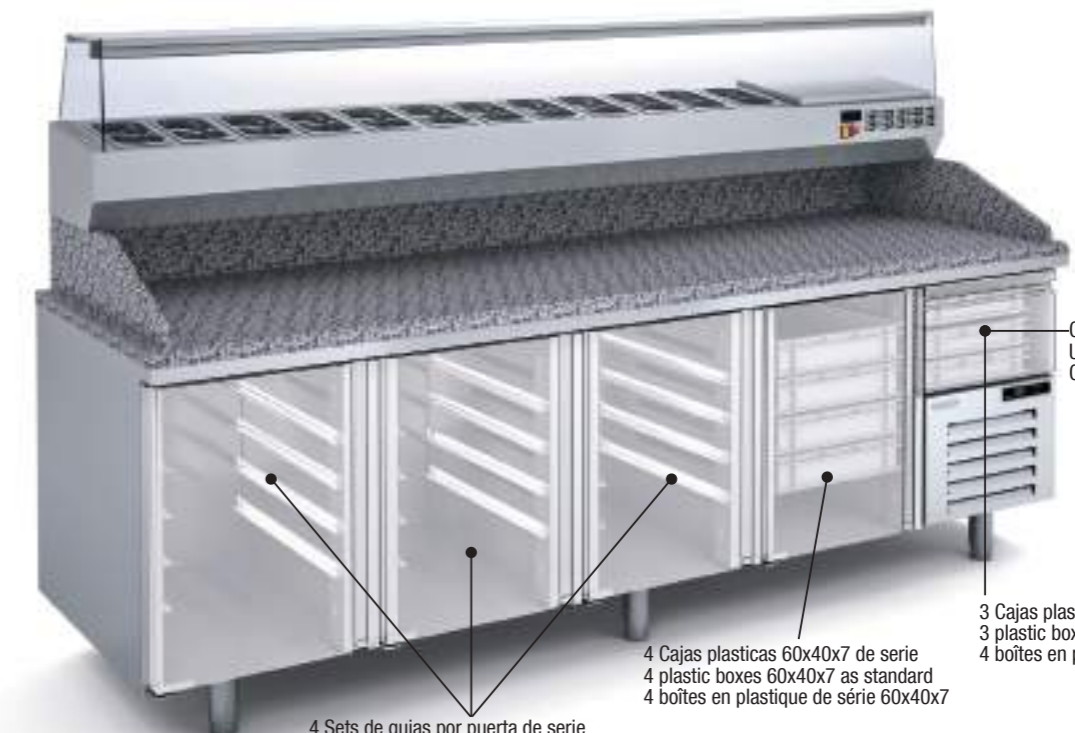

Cajon no refrigerado  
Uncooled drawer  
Cajon non refroidi

**MP-80-265-R**

4 Sets de guías por puerta de serie  
4 Sets of guides per standard door  
4 séries par séries de guides de porte

3 Cajas plasticas 60x40x7 de serie  
3 plastic boxes 60x40x7 as standard  
4 boîtes en plastique de série 60x40x7

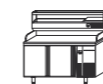

MP-80-160-R **4.533 €**

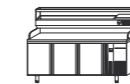

MP-80-210-R **5.295 €**

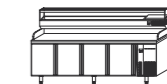

MP-80-265-R **6.072 €**

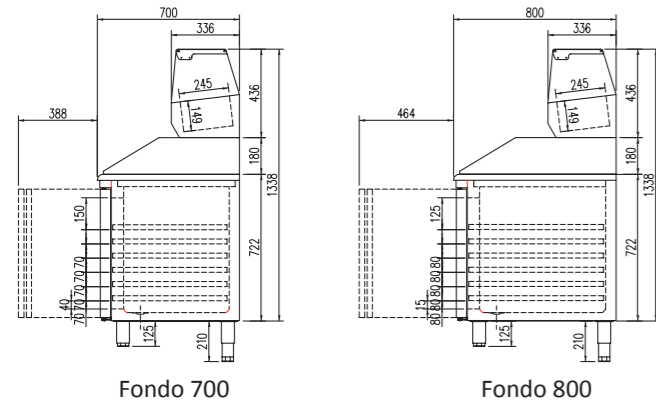

Detalle set 7 cajones opcional  
Detail set 7 drawers optional  
7 tiroirs détail en option



**MPC-70-225**

1 Parrilla + juego guías GN 1/1 por puerta de serie  
1 Grill + set GN 1/1 guides per standard door  
1 Grill + guide jeu GN 1/1 par porte standard

4 Cajones neutros  
4 Neutral drawers  
4 tiroirs neutres



**MPC-80-250**

5 Sets de guías por puerta de serie  
5 Sets of guides per standard door  
5 séries par séries de guides de porte

4 Cajones neutros + 5 cajas plasticas 60x45x7 de serie  
4 Neutral drawers, plastic boxes not included  
4 Tiroirs neutres + 5 boîtes en plastique de 60x45x7 série

**CARACTERÍSTICAS TÉCNICAS**

- Encimera de granito, con peto trasero y laterales de 180 mm
- Expositor de ingredientes incluido, capacidad cubetas GN 1/4, (No incluidas)
- Interior con guías de acero inox, regulables en altura para parrillas, bandejas o contenedores
- Cuerpo cajonero neutro, 4 cajones sobre guías telescópicas desmontables

**TECHNICAL DATA**

- Granite working surface with 180 mm up stands
- Ingredient display included, capacity GN 1/4 cuvettes, (Not included)
- Inner with stainless steel guides, adjustable in height for grills, trays or containers
- Neutral drawer body, 4 drawers on removable telescopic guides

**CARACTÉRISTIQUES TECHNIQUES**

- Plan de travail en granit, avec pente arrière et côtés de 180 mm
- Ingrédients exposants inclus Capacité 1/4 bacs GN (non inclus)
- Intérieur de guidage en acier inoxydable, des supports réglables en hauteur, des plateaux ou récipients
- Corps cajonero neutre, 4 tiroirs amovibles sur glissières télescopiques

Ver características técnicas en página 250 / See technical data in page 250 / Voir caractéristiques techniques page 250

\* Gas opcional / \* Optional gas / \* Gaz optionnel

Modelo Model Modèle	Largo Length Longueur mm	Alto Height Hauteur mm	Fondo Depth Profondeur mm	Rango Range Gamme	Estantes Shelves Étagères	Pares de guías Sets of slides Kit de guides	Cajas Containers Boîtes 40x60	Capacidad Capacity Exposition L	Capacidad GN GN Capacity Exposition GN Uds	Voltaje Voltage Tension	Refrig. Coolant Frigorigène	Potencia Frig. Frig Power Puissance Frig. W	Consumo Nominal Nominal Consumption Consommation Nominale W
MPC-70-180	1795	850	700	0°C +8°C	2	2	0	255	8	230 V - 50 Hz	R-290	502	235
MPC-70-225	2245	850	700	0°C +8°C	3	3	0	399	10	230 V - 50 Hz	R-290	502	238
MPC-80-200	2020	850	800	0°C +8°C	0	10	5	362	9	230 V - 50 Hz	R-290	502	235
MPC-80-250	2545	850	800	0°C +8°C	0	15	5	562	12	230 V - 50 Hz	R-290	502	238

**OPCIONES - OPTIONS - OPTIONS**

Parrilla adicional 530 X 325 GN1/1	530 X 325 GN1/1 extra shelf	Grille additionnelle 530 X 325 GN1/1	25 € x ud
Set 7 cajones en gama 800	7 drawers set in range 800	7 tiroirs dans la gamme 800	270 €
Cerradura puerta inox	Solid door lock	Serrure à porte inox	25 € x ud
Motor lado izquierdo	Left side engine	Moteur côté gauche	73 €
Set 4 ruedas	4 Castors set	Jeu 4 roulettes	98 € x set
Set 6 ruedas	6 Castors set	Jeu 6 roulettes	146 € x set
Registrador de alarmas haccp	Haccp alarm recorder	Enregistreur d'alarme HACCP	consultar - consult- consulter
Respaldo inox	Stainless steel rear side	Soutien en inox	consultar - consult- consulter
230V 60hz / 115v 60hz	230V 60hz / 115v 60hz	230v 60Hz / 115v 60Hz	consultar - consult- consulter

Características técnicas y constructivas sujetas a variación sin previo aviso. / We reserve the right to change specifications without prior notice. / Sujet technique et la conception de modifications sans préavis.

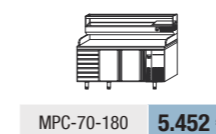

MPC-70-180 **5.452 €**

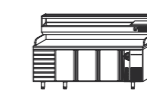

MPC-70-225 **6.221 €**

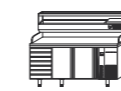

MPC-80-200 **5.504 €**

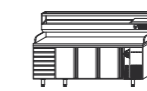

MPC-80-250 **6.624 €**

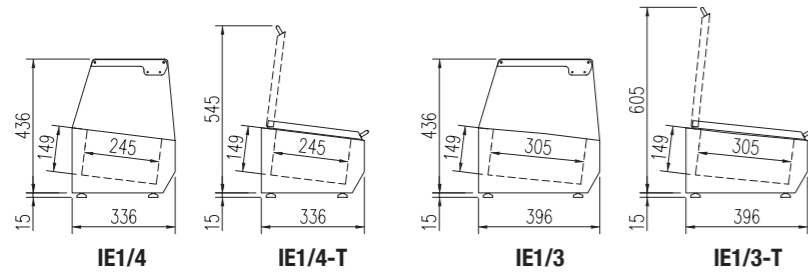

Detalle tapa cerrada  
Closed lid detail  
Détail du couvercle fermé

CARACTERÍSTICAS TÉCNICAS IE	TECHNICAL DATA IE	CARACTÉRISTIQUES TECHNIQUES IE
<ul style="list-style-type: none"> <li>Exterior e interior en acero inox AISI-304 18/10</li> <li>Capacidad para cubetas GN no incluidas</li> <li>Apoyos regulables en altura</li> <li>Evaporador por placa fría</li> <li>Aislamiento de poliuretano inyectado, densidad 40 Kg/m<sup>3</sup>, bajo GWP y cero efecto ODP</li> <li>Control digital de temperatura y descargas, eficiente en la gestión del consumo de energía</li> <li>Temperatura de trabajo +2°C +8°C a 32°C ambiente</li> <li>El cúpula de cristal</li> <li>El T cubierta inox abatible</li> </ul>	<ul style="list-style-type: none"> <li>AISI-304 18/10 stainless steel exterior and interior</li> <li>GN containers capacity, not included</li> <li>Adjustable supports</li> <li>Cold plate evaporator</li> <li>40 Kg/m<sup>3</sup> density polyurethane insulation, low GWP and zero ODP effect</li> <li>Energy efficient digital controller of temperature and defrosts</li> <li>Operating temperature +2°C +8°C , 32°C ambient</li> <li>El glass cover options</li> <li>El-T hinged stainless steel cover</li> </ul>	<ul style="list-style-type: none"> <li>Extérieur en acier inoxydable AISI 304 18/10,</li> <li>Possibilité d'intégrer bacs, GN non inclus.</li> <li>Supports réglables en hauteur.</li> <li>Evaporateur avec système de plaque froide.</li> <li>Isolation à base de polyuréthane injecté, densité 40 kg/m<sup>3</sup>, faible GWP et aucun effet ODP.</li> <li>Le Contrôle digital de température ainsi que le dégivrage automatique œuvre à une meilleure gestion de la consommation énergétique.</li> <li>Température de travail +4°C à +8°C, à 32°C de température ambiante.</li> <li>IE : dôme en verre</li> <li>IE T: Couvercle en inox rabattable</li> </ul>



IE 1/4-200-T

\* Gas opcional / \* Optional gas / \* Gaz optionnel

Modelo Model Modèle	Largo Length Longueur mm	Fondo Depth Profondeur mm	Rango Range Gamme	Capacidad Capacity Exposition GN 1/4	Capacidad Capacity Exposition GN 1/3	Voltaje Voltage Tension	Refrig. Coolant Frigorigène	Potencia Frig. Frig Power Puissance Frig. W	Consumo Nominal Nominal Consumption Consommation Nominale W (IE-T)	Consumo Nominal Nominal Consumption Consommation Nominale W (IE)
IE-1/4-135	1345	336	+2°C +8°C	5	0	230 V - 50 Hz	R-290	158	131	152
IE-1/4-150	1495	336	+2°C +8°C	6	0	230 V - 50 Hz	R-290	170	134	155
IE-1/4-180	1795	336	+2°C +8°C	8	0	230 V - 50 Hz	R-290	190	136	162
IE-1/4-200	2020	336	+2°C +8°C	9	0	230 V - 50 Hz	R-290	200	138	180
IE-1/4-225	2245	336	+2°C +8°C	10	0	230 V - 50 Hz	R-290	502	203	245
IE-1/4-250	2545	336	+2°C +8°C	12	0	230 V - 50 Hz	R-290	502	203	245
IE-1/3-135	1345	396	+2°C +8°C	0	5	230 V - 50 Hz	R-290	158	131	152
IE-1/3-150	1495	396	+2°C +8°C	0	5	230 V - 50 Hz	R-290	170	134	155
IE-1/3-180	1795	396	+2°C +8°C	0	7	230 V - 50 Hz	R-290	190	136	162
IE-1/3-200	2020	396	+2°C +8°C	0	8	230 V - 50 Hz	R-290	200	138	180
IE-1/3-225	2245	396	+2°C +8°C	0	10	230 V - 50 Hz	R-290	502	203	245
IE-1/3-250	2545	396	+2°C +8°C	0	11	230 V - 50 Hz	R-290	502	203	245



IE 1/3-180

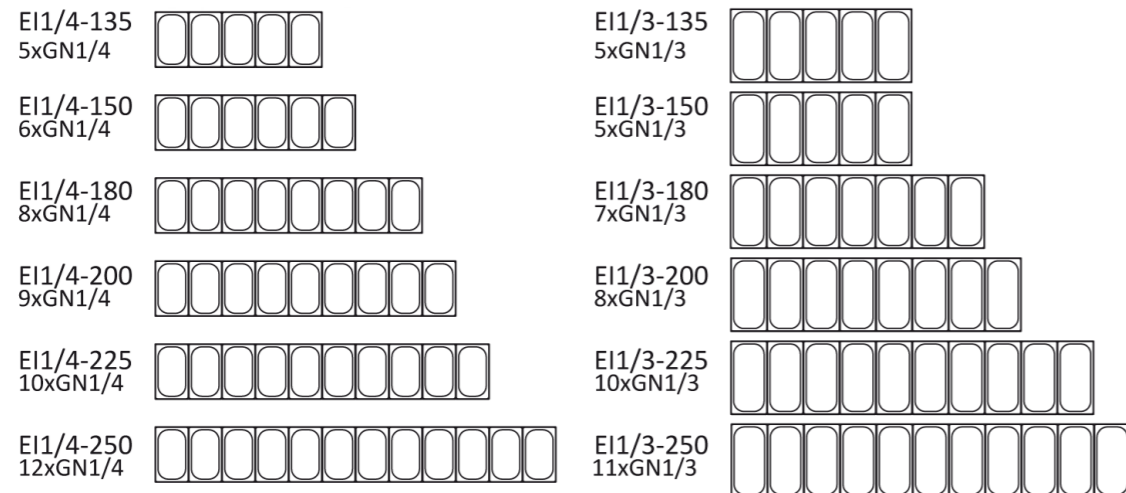

 IE-1/4-135-T <b>1.320 €</b>  IE-1/3-135-T <b>1.386 €</b>	 IE-1/4-150-T <b>1.367 €</b>  IE-1/3-150-T <b>1.435 €</b>	 IE-1/4-180-T <b>1.488 €</b>  IE-1/3-180-T <b>1.554 €</b>	 IE-1/4-200-T <b>1.521 €</b>  IE-1/3-200-T <b>1.595 €</b>	 IE-1/4-225-T <b>1.649 €</b>  IE-1/3-225-T <b>1.728 €</b>	 IE-1/4-250-T <b>1.736 €</b>  IE-1/3-250-T <b>1.810 €</b>
 IE-1/4-135 <b>1.499 €</b>  IE-1/3-135 <b>1.554 €</b>	 IE-1/4-150 <b>1.521 €</b>  IE-1/3-150 <b>1.583 €</b>	 IE-1/4-180 <b>1.629 €</b>  IE-1/3-180 <b>1.689 €</b>	 IE-1/4-200 <b>1.688 €</b>  IE-1/3-200 <b>1.750 €</b>	 IE-1/4-225 <b>1.769 €</b>  IE-1/3-225 <b>1.798 €</b>	 IE-1/4-250 <b>1.889 €</b>  IE-1/3-250 <b>1.877 €</b>

Características técnicas y constructivas sujetas a variación sin previo aviso. / We reserve the right to change specifications without prior notice. / Sujet technique et la conception de modifications sans préavis.